



ETOILE

 **lafano**
oltre l'ufficio

COMPANY PROFILE

ETOILE

lafano
oltre l'ufficio

INDEX



MAJOR PROJECTS

Novo Nordisk

Moscow - Russia - 2018

Fora Space

- 42 Berners Street
 - Southwark Bridge Road
 - Arnold House
- London - UK - 2019

Sunglass

Padua - Italy - 2018

Rael

Predosa - Italy - 2019



PRODUCTS

unica[®]

ritmica[®] aluminium

ritmica[®] wood

metrica[®] structural

metrica[®] frameless

quadra[®] storage

dodici[®] furniture collection



FINISHES



COMPANY

**A ten-years
long** history
thirty years
in this field



People / Technologies / Know-how

COMPANY

Etoile is a leading Company in the field of partition walls production and office furniture.

It offers a wide and versatile range of solutions and products

Consultancy
Design
Customer Care



ETOILE

lafano
oltre l'ufficio

ETOILE

lafano
oltre l'ufficio

ETOILE



italy/marche/fano/etoile

MADE IN ITALY
Italian Style from
design to construction

ETOILE

lafano
oltre l'ufficio

QUALITY AND ENVIRONMENT

The Etoile business cycles require great attention and total respect for the environment.



ETOILE

lafano
oltre l'ufficio

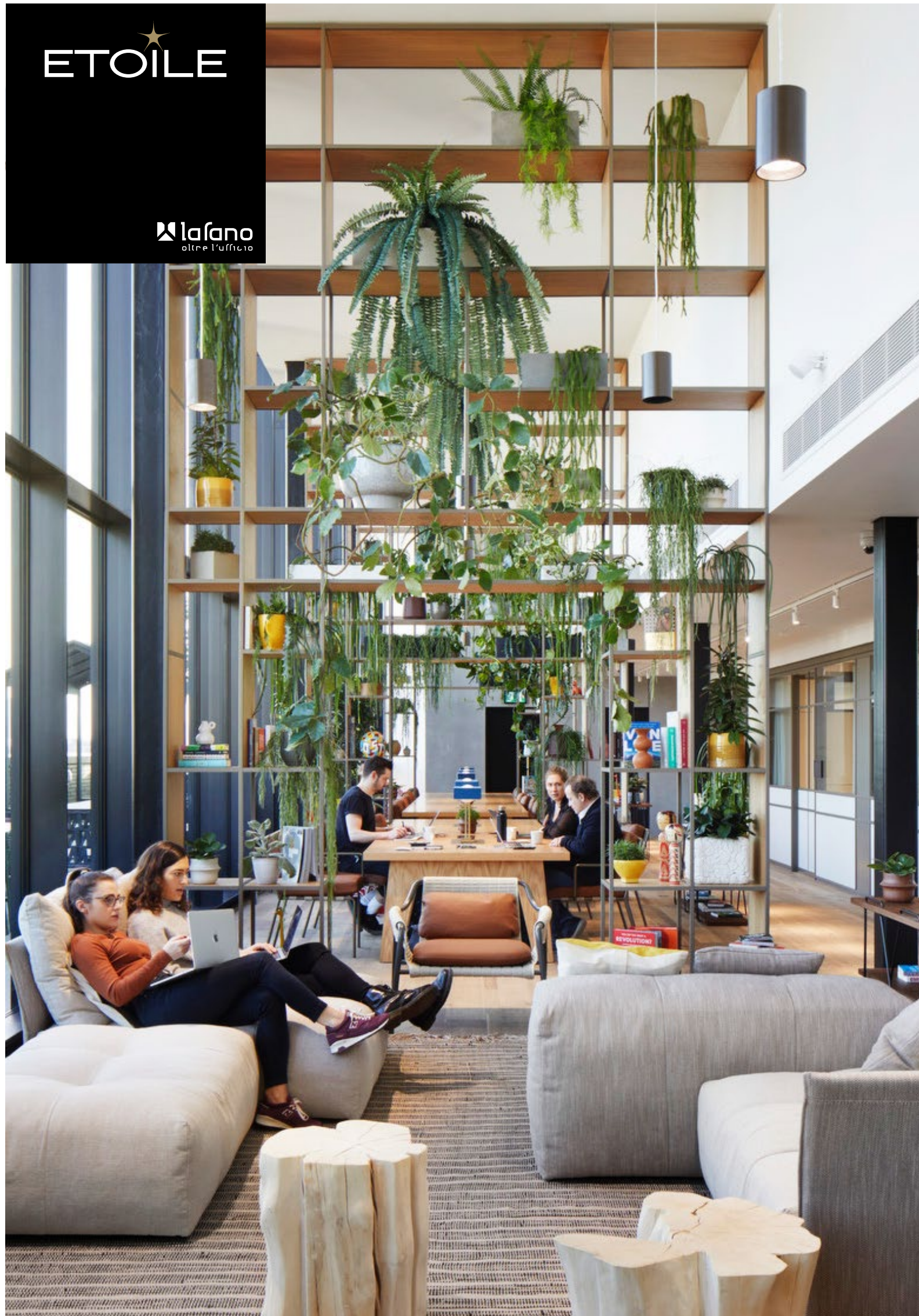

QUALITY AND ENVIRONMENT



COMPANY:

We only use energy from certified renewable sources.

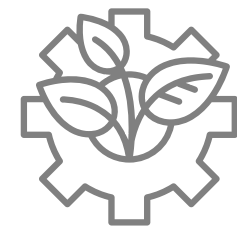

OUR PRODUCTION:

Eco-sustainable solutions thanks to the use of avant-garde technologies that combine aesthetics and functionality.

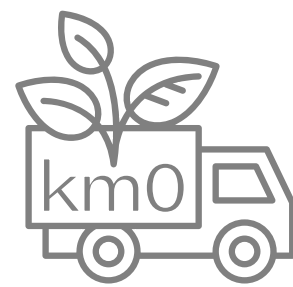

OUR SUPPLIERS:

Only selected and local suppliers to ensure highest excellence and respect for the environment.



ISO 9001:2015 CERTIFICATION

Product certifications: acoustics, fire resistance, mechanics, safety.



STRONG POINTS

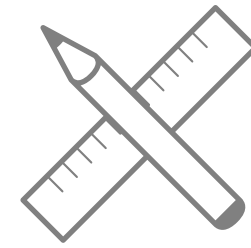

DESIGN AND CUSTOMIZATION

Our tech office and our designers tailor each product to perfectly fit the room, finding the best solution to meet both the functional and the aesthetical requirements the client needs.

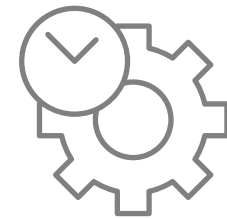

MANUFACTURING

Having a constant exchange with our tech department, the factory can manufacture our products and have them ready for shipping in a 48-hours average.

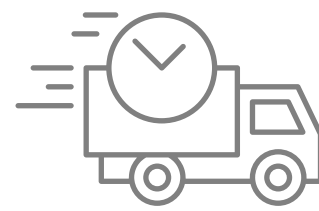

DELIVERY

The 100% of our orders are being delivered on schedule thanks to the certified network of transport companies we deal with.

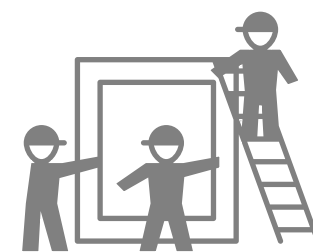

ASSEMBLY

Our assembly times are fast and efficient thanks to our highly-skilled installation teams, working with us since many years so far.

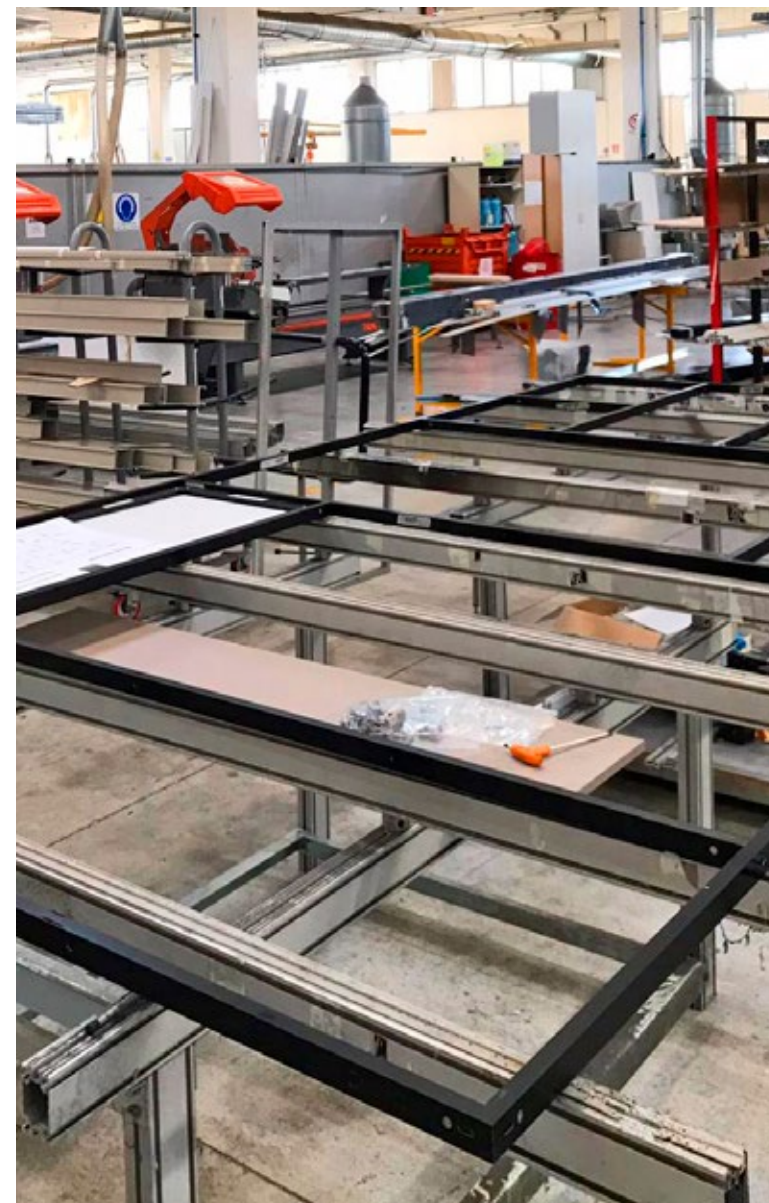

ETOILE

lafano
oltre l'ufficio



ETOILE

 **lafano**
oltre l'ufficio

MAJOR PROJECTS

ETOILE

lafano
oltre l'ufficio

MAJOR PROJECTS



Novo Nordisk

Moscow - Russia - 2018

metrica® d2

metrica® solid

metrica® v



Sunglass

Padua - Italy - 2018

unica® sc2



Fora Space

- 42 Berners Street

- Southwark Bridge Road

- Arnold House

London - UK - 2019



fora style®

metrica® solid



Rael

Predosa - Italy - 2019

metrica® solid

metrica® d2

quadra® dodici

ETOILE

lafano
oltre l'ufficio



Novo Nordisk
Moscow - Russia - 2018



900 Sq.m.
of partitions

Bright and transparent spaces, equipped with sound-absorbing and sound-insulating panels for a major acoustic comfort.

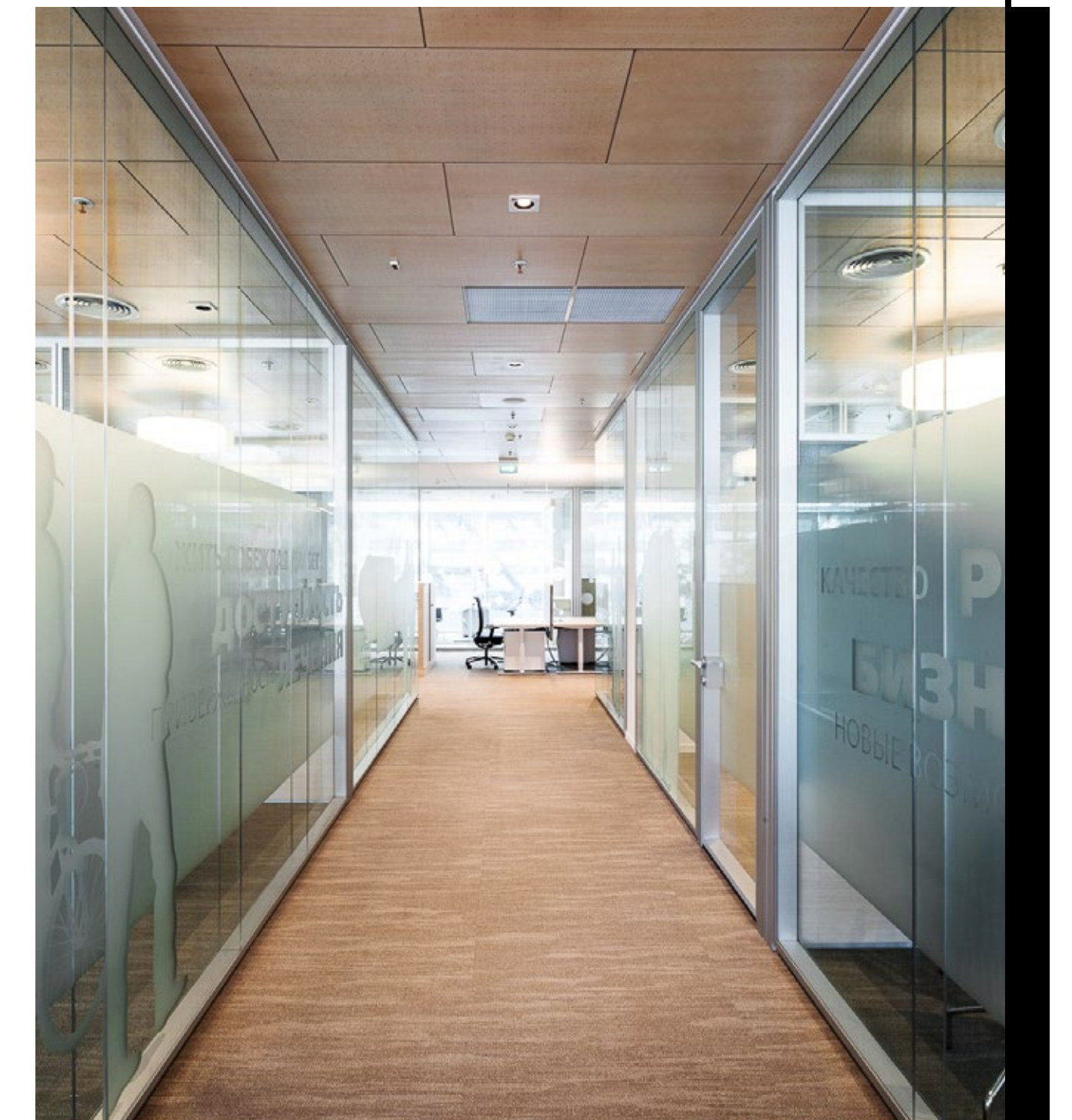

ETOILE

lafano
oltre l'ufficio

Novo Nordisk
Moscow - Russia - 2018

ETOILE

lafano
oltre l'ufficio

metrica[®] d2
metrica[®] solid
metrica[®] v

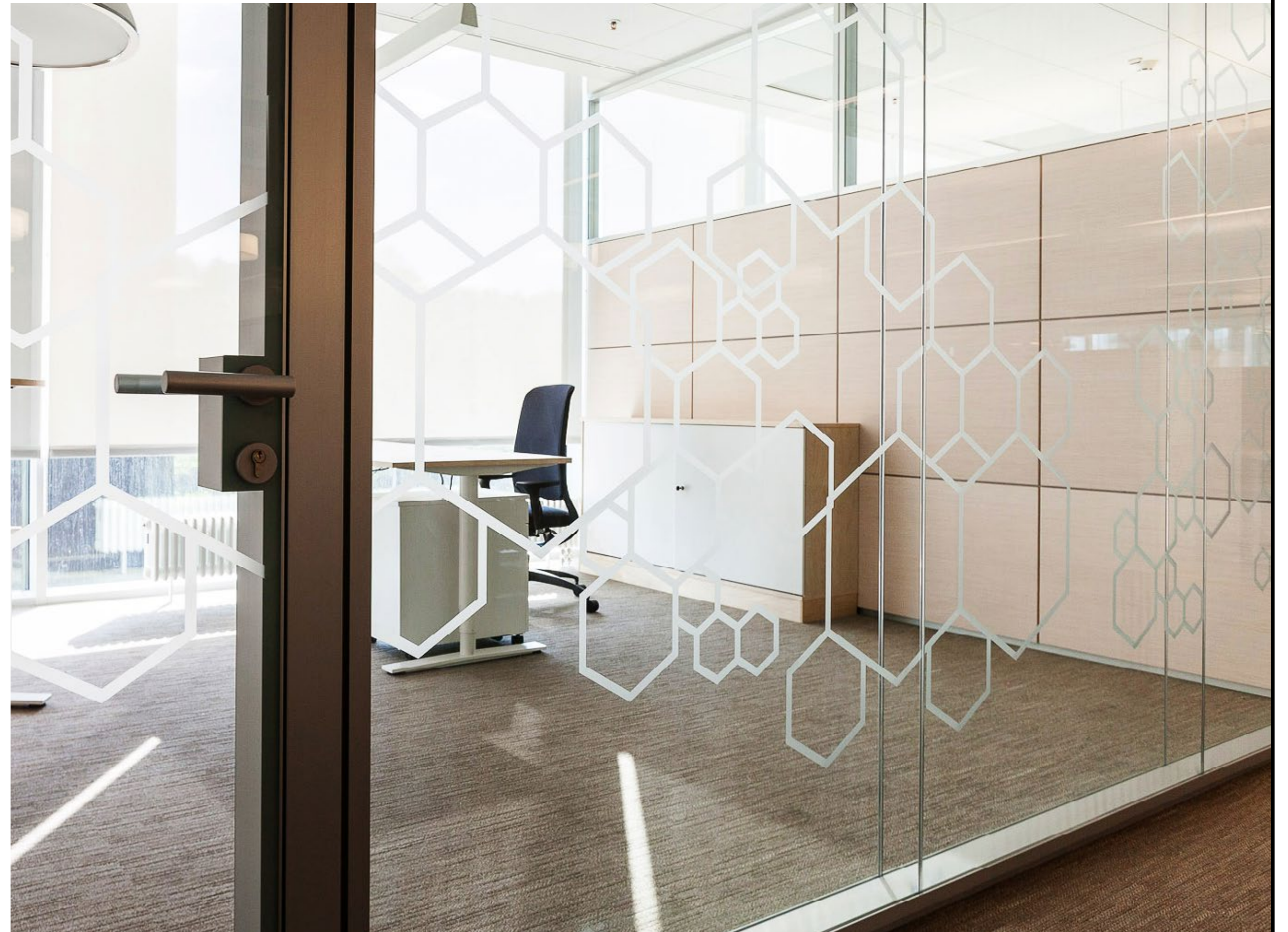

Soundproofing
from 40 to 47 db

Novo Nordisk
Moscow - Russia - 2018

Materials used:
glass, wood, fabric

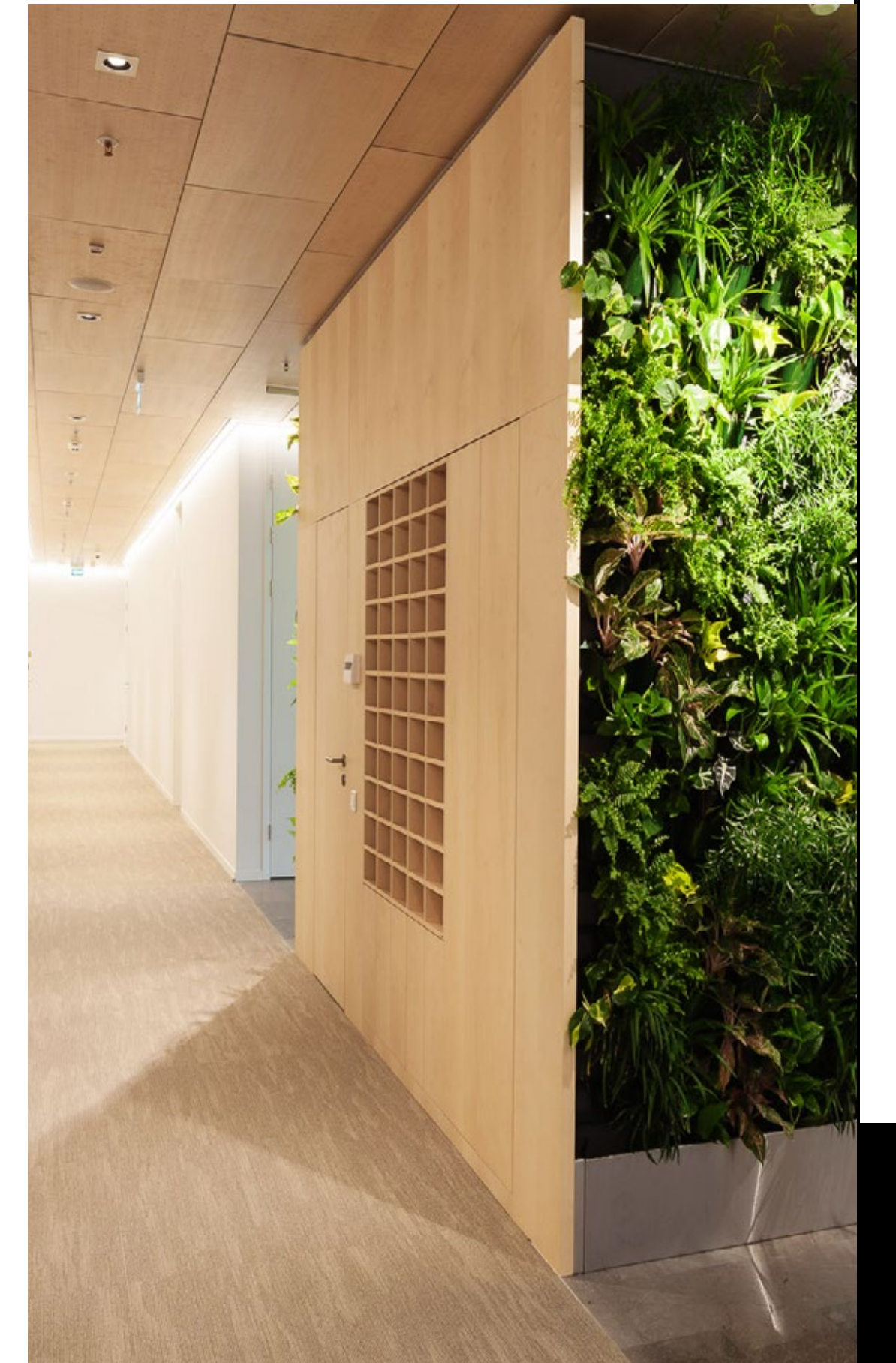
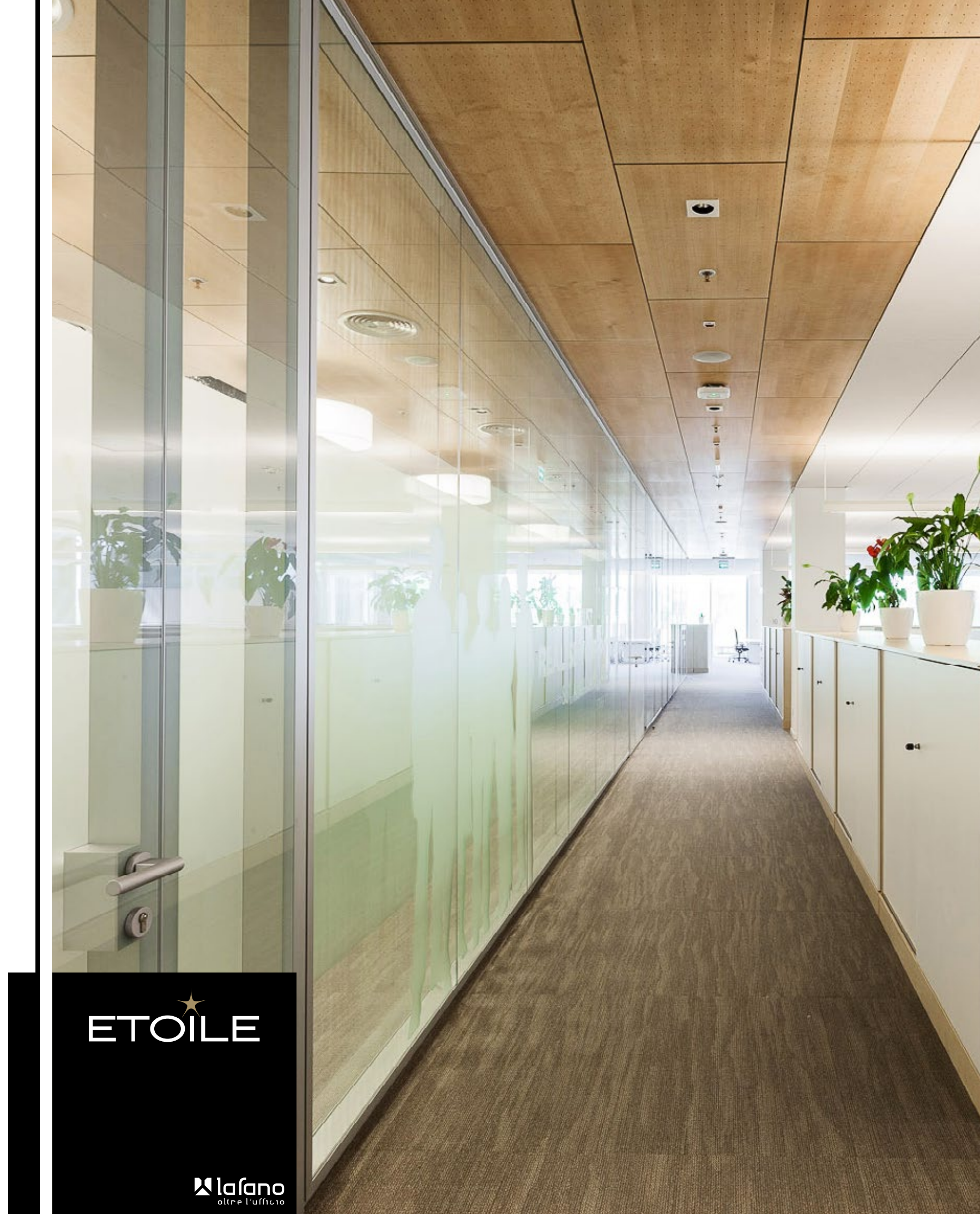

Novo Nordisk
Moscow - Russia - 2018

ETOILE

lafano
oltre l'ufficio



Fora Space
42 Berners Street - London - UK - 2019

ETOILE

lafano
oltre l'ufficio



1.500 Sq.m.
of partitions

Amazing working spaces,
highly professional and flexible.
This is the mission of our
client Fora.

fora style[®]
metrica[®] solid

Fora Space

42 Berners Street - London – UK - 2019

ETOILE

lafano
oltre l'ufficio

Materials used:
glass, wood, fabric



Fora Space
42 Berners Street - London - UK - 2019

ETOILE

lafano
oltre l'ufficio

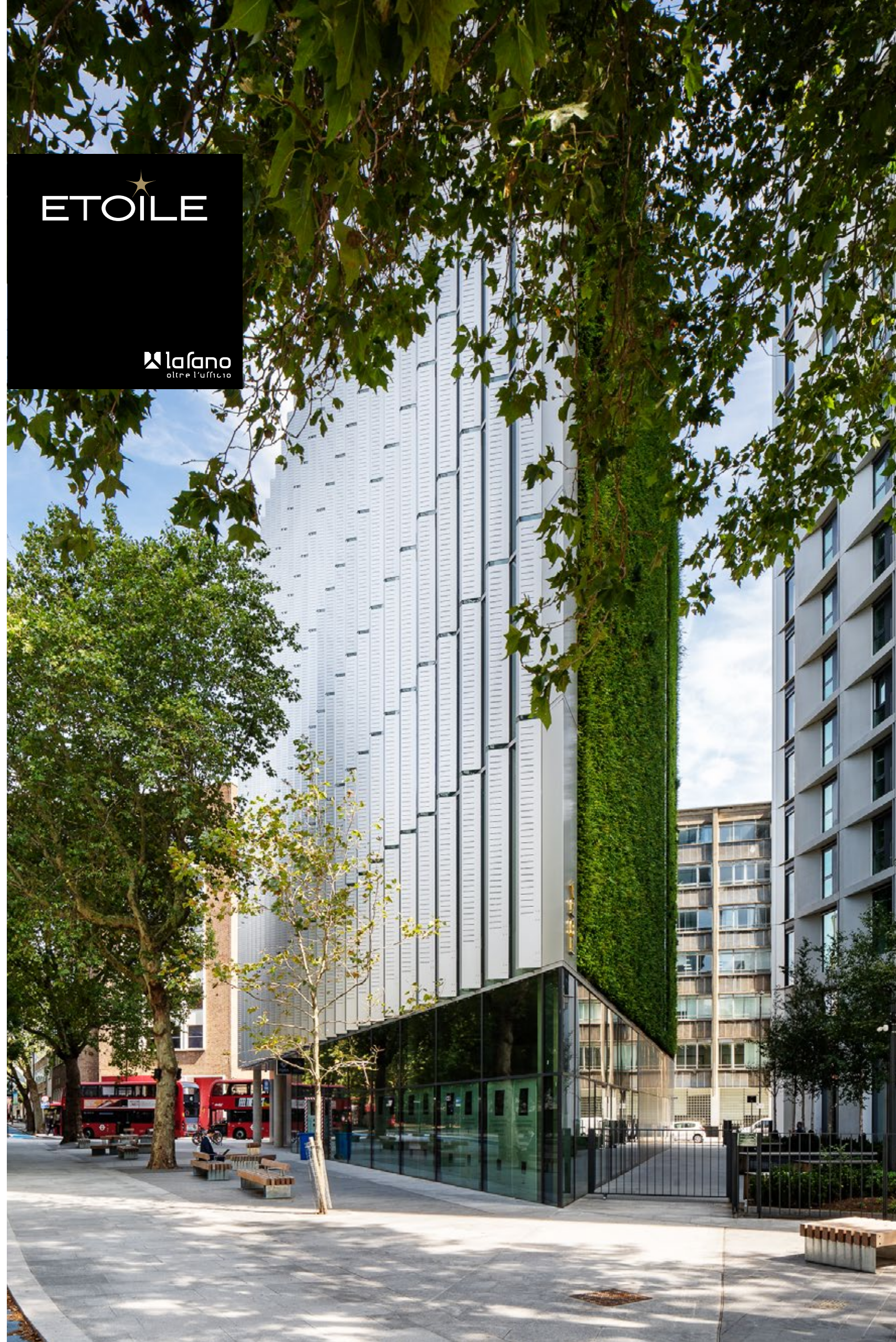

Fora Space
Southwark Bridge Road
London – UK – 2019



900 Sq.m. of partitions

Creating vibrantly functional working spaces, designed to enhance productivity, inspiration and cooperation.

Fora Space
Southwark Bridge Road
London – UK - 2019

ETOILE

lafano
oltre l'ufficio

ETOILE

lafano
oltre l'ufficio

fora style[®]
metrica[®] solid

Materials used:
glass, wood,
fabric



Fora Space
Southwark Bridge Road
London – UK – 2019



ETOILE

lafano
oltre l'ufficio



Fora Space
Arnold House - London - UK - 2019

ETOILE

lafano
oltre l'ufficio



1.500 Sq.m.
of partitions

All the spaces are showered
by natural light and enriched
with an open courtyard and
roof terraces.

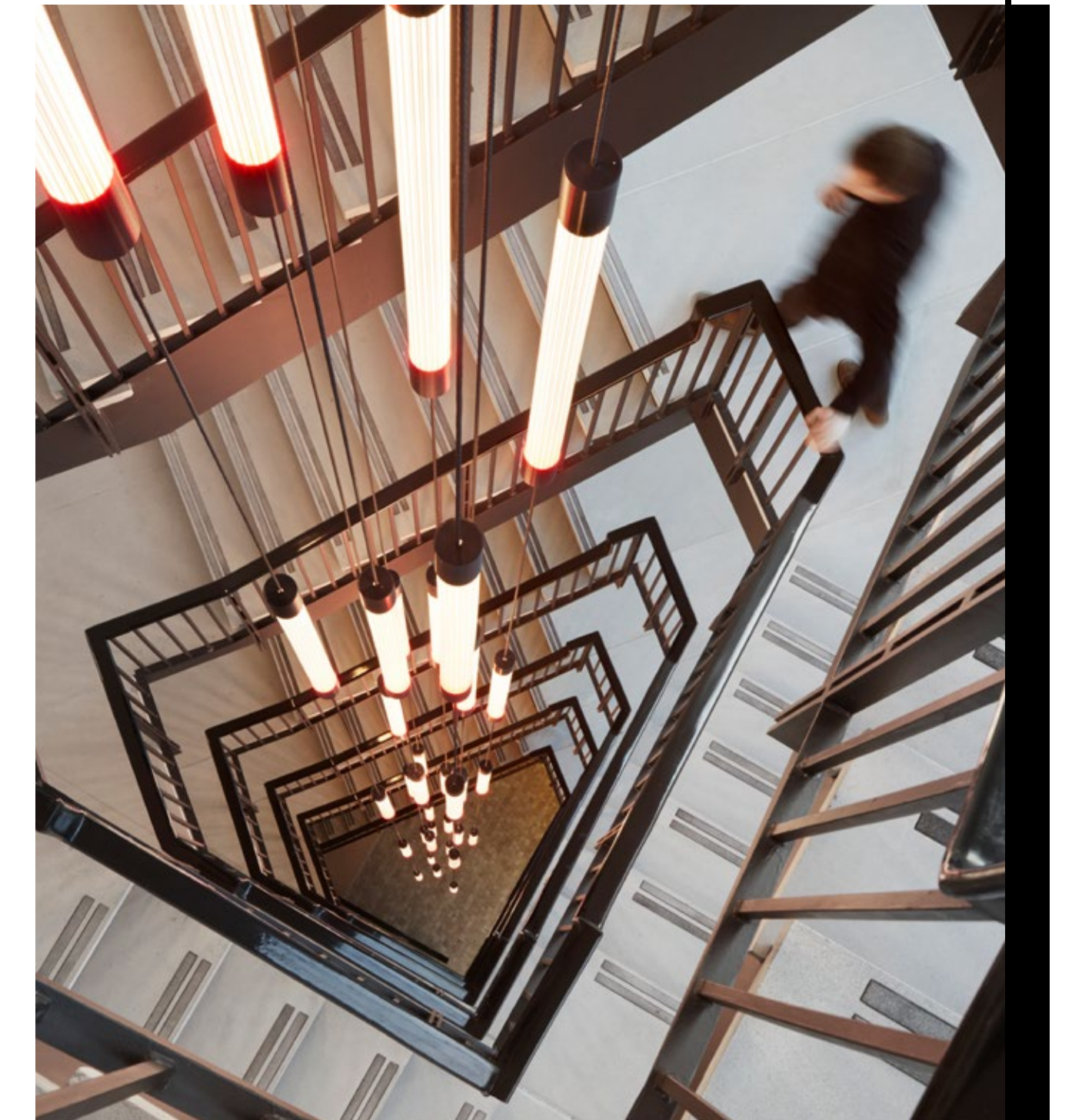

Fora Space
Arnold House - London - UK - 2019

ETOILE

lafano
oltre l'ufficio

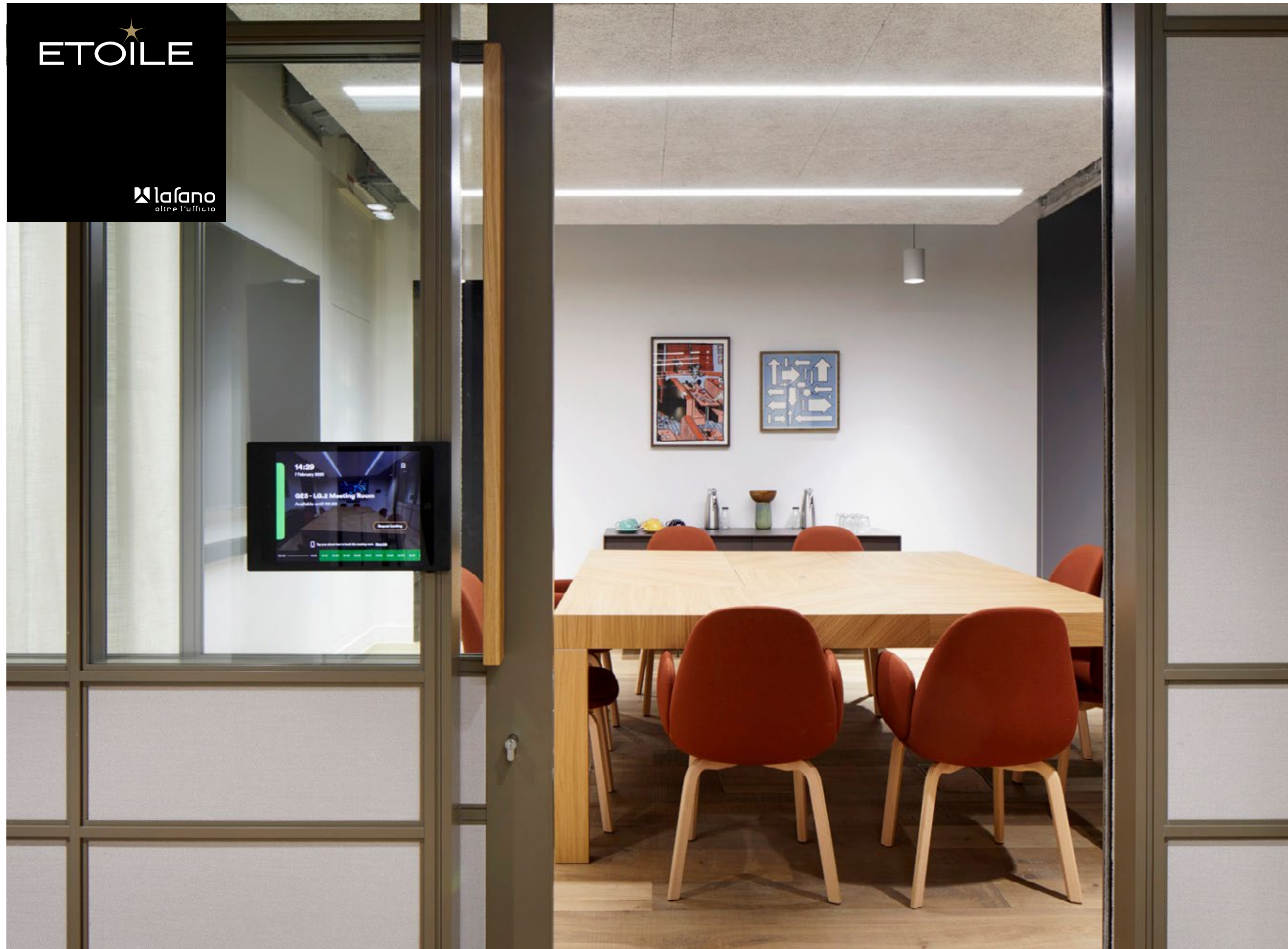

fora style®
metrica® solid

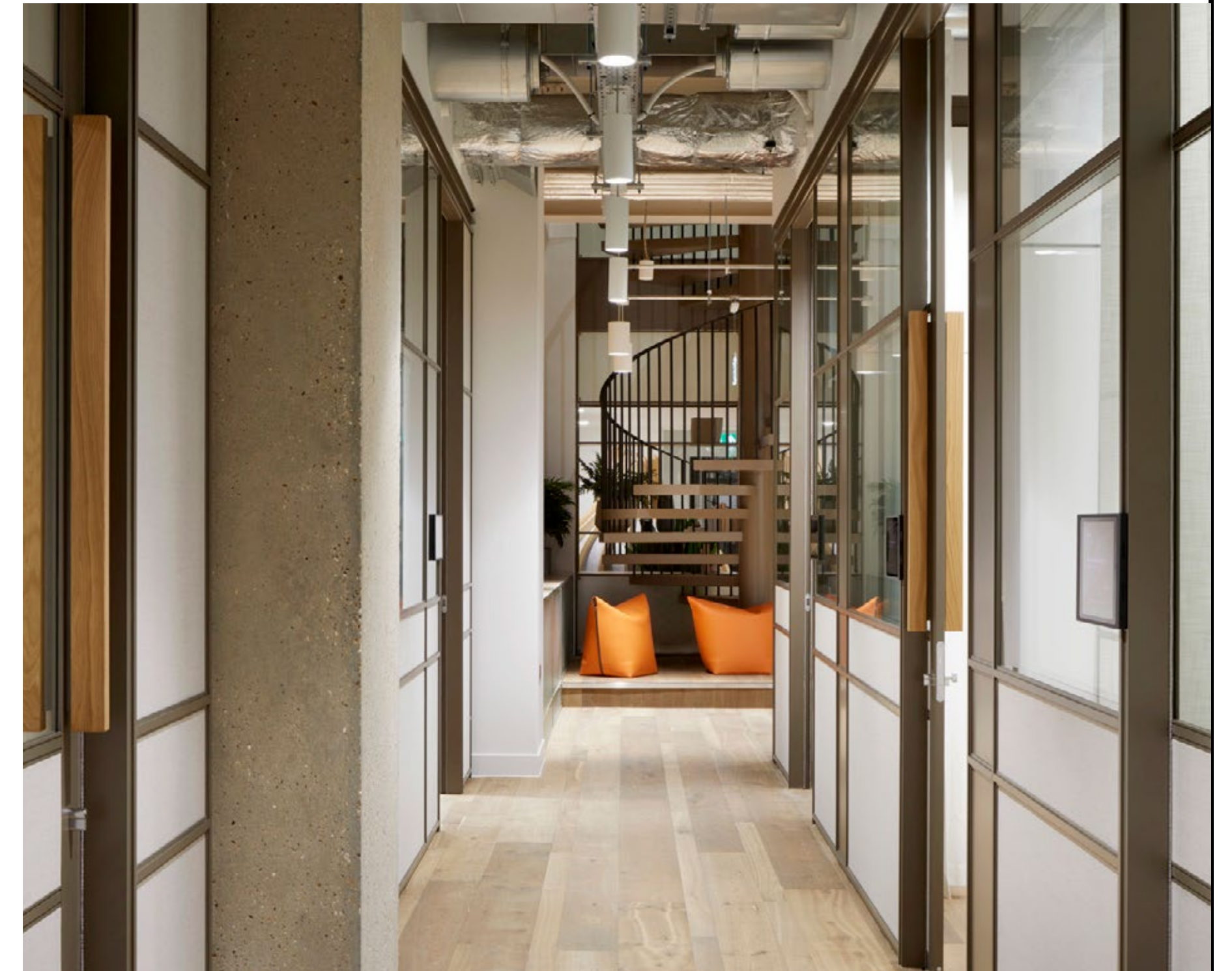

Fora Space
Arnold House - London - UK - 2019

Materials used:
glass, wood, fabric

ETOILE

lafano
oltre l'ufficio



Sunglass
Padua - Italy - 2018

ETOILE

lafano
oltre l'ufficio

500 Sq.m. of partitions



Sunglass
Padua - Italy - 2018



ETOILE

lafano
oltre l'ufficio

Soundproofing
40 db

Sunglass
Padua - Italy - 2018

ETOILE

lafano
oltre l'ufficio

unica[®] sc2
Materials used:
glass, wood

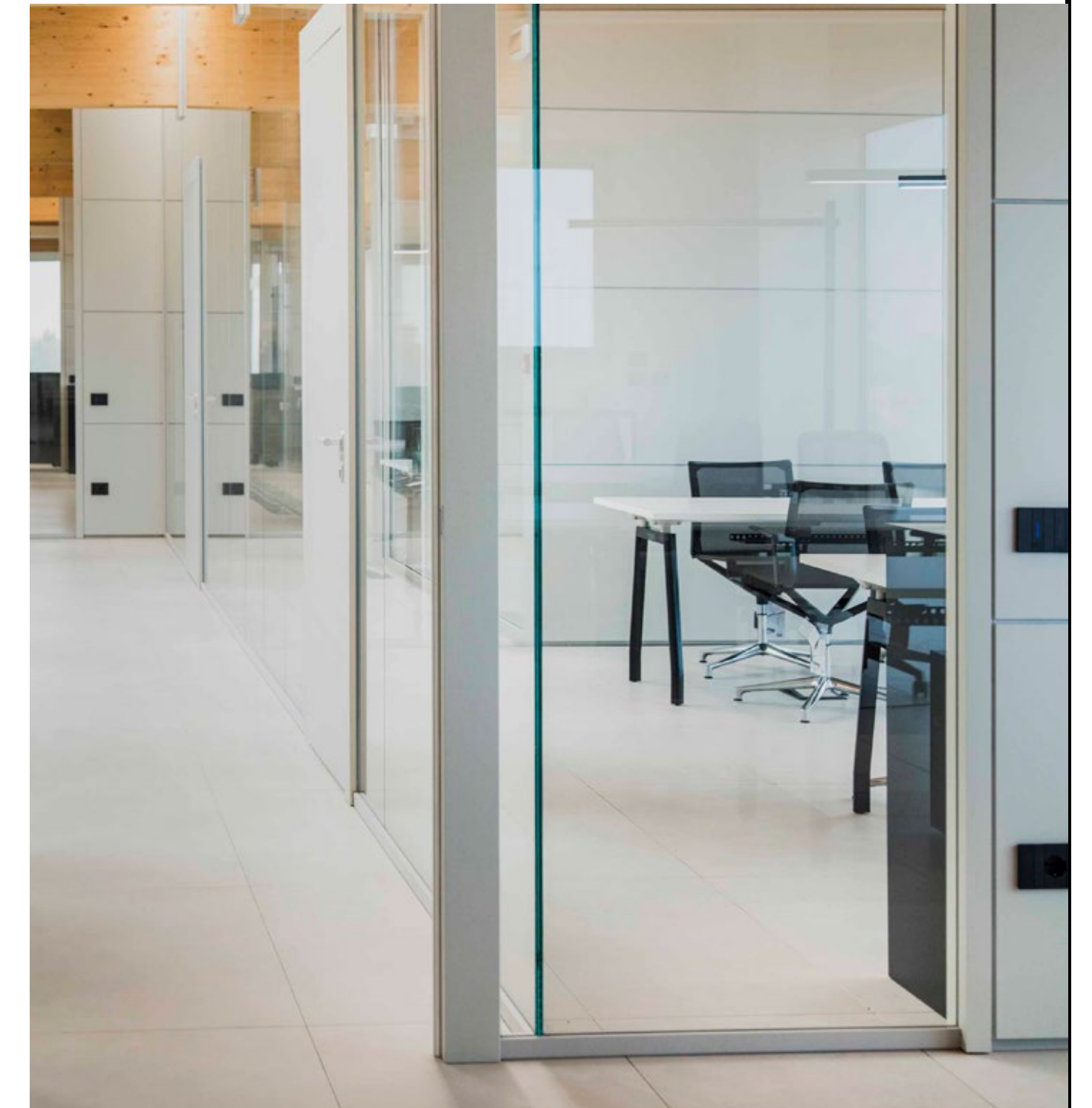

Sunglass
Padua - Italy - 2018

ETOILE

lafano
oltre l'ufficio



Unica® full single glazed partitions,
with extra-clear acoustic glass
and high soundproofing rate



Sunglass
Padua - Italy - 2018

ETOILE

lafano
oltre l'ufficio



Rael
Predosa - Italy - 2019

ETOILE

lafano
oltre l'ufficio



Rael
Predosa - Italy - 2019

Materials used:
**glass, wood,
laminam**

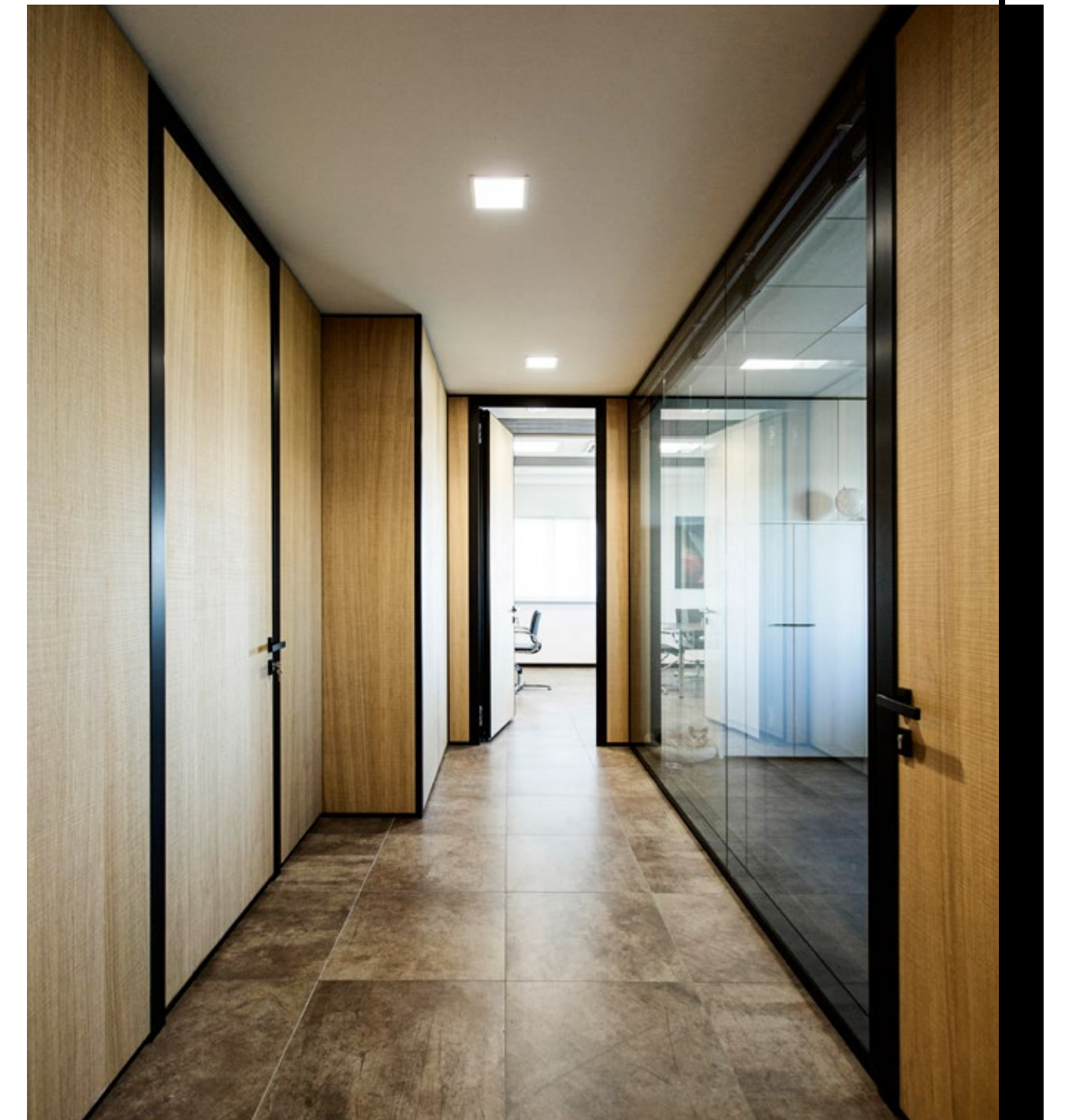

ETOILE

lafano
oltre l'ufficio

450 Sq.m. of partitions



Rael
Predosa - Italy - 2019

ETOILE

lafano
oltre l'ufficio



metrica[®] solid
metrica[®] d2
quadra[®] dodici



Rael
Predosa - Italy - 2019

Materials used:
glass, wood, laminam



ETOILE

 **lafano**
oltre l'ufficio

P R O D U C T S

ETOILE

lafano
oltre l'ufficio

PRODUCTS



ritmica®
aluminium

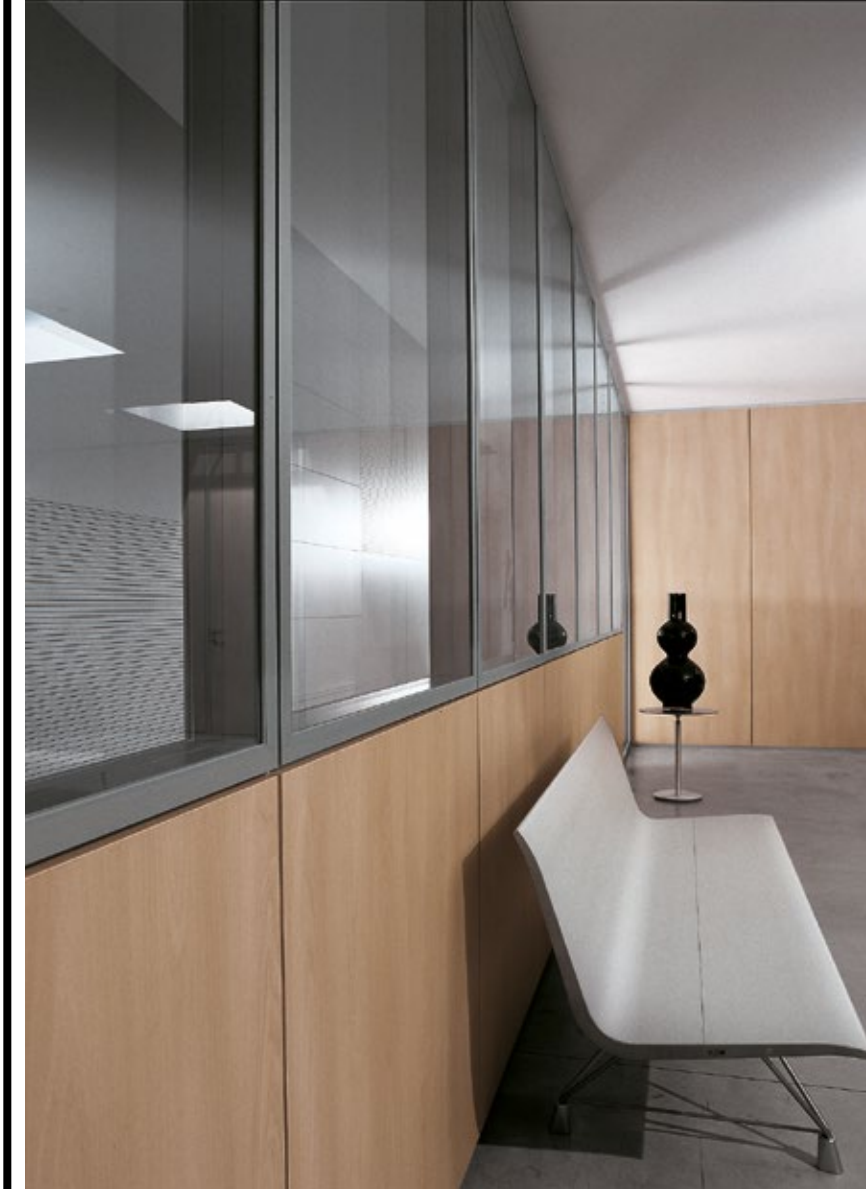

metrica®
structural



quadra®
storage



unica®

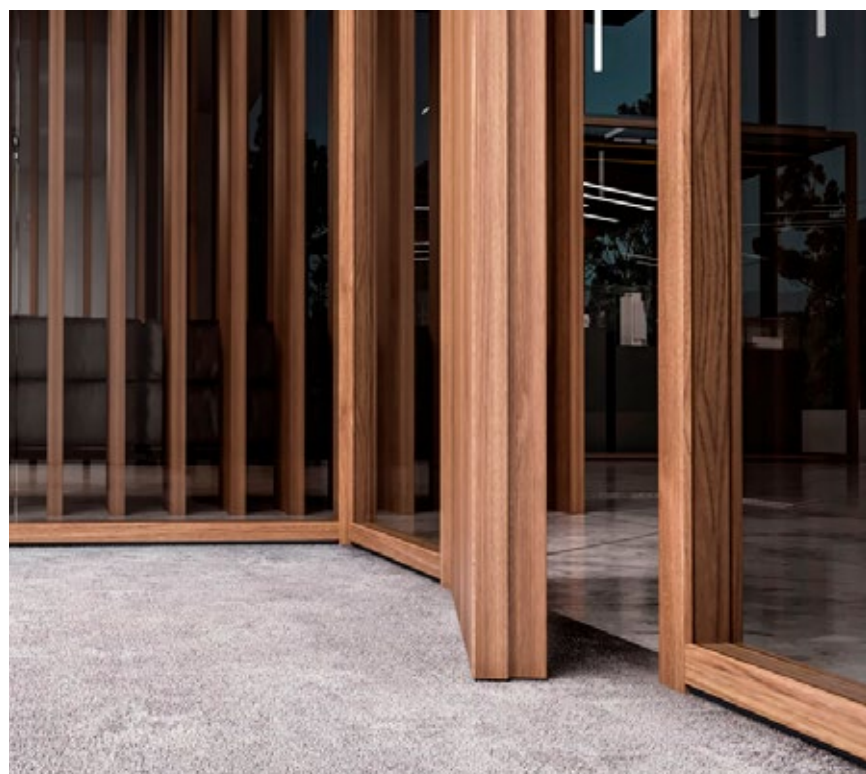

ritmica®
wood



metrica®
frameless



dodici®
furniture collection



unica®

51-mm thick Partition Wall
(single glass, double glass, solid)

Unica is a partition designed to satisfy both the operational and the aesthetic requirements of innovative and comfortable working spaces. Its main characteristics are the minimal design, the thin 51-mm total thickness of its metal structure and the high level of custom-tailoring it can reach under the aesthetic and operational point of view.

It is also designed to hold suspended storages, shelves, curtains and coat hangers, thanks to its special vertical stud, expressly designed for this purpose.

ETOILE

lafano
oltre l'ufficio



ETOILE

lafano
oltre l'ufficio

unica®

51-mm thick
Partition Wall

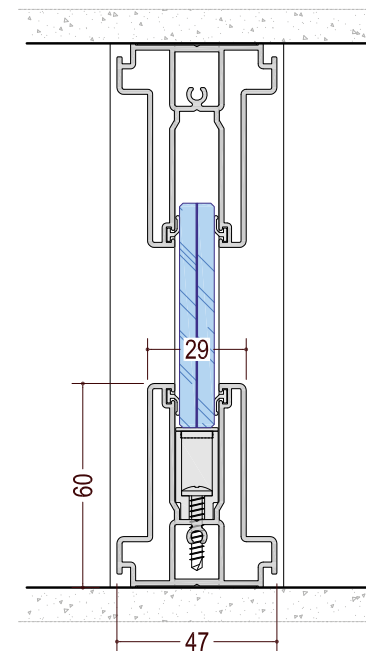

unica® r

Single glazed partition.
Acoustic performance:
from 32 to 35 dB.

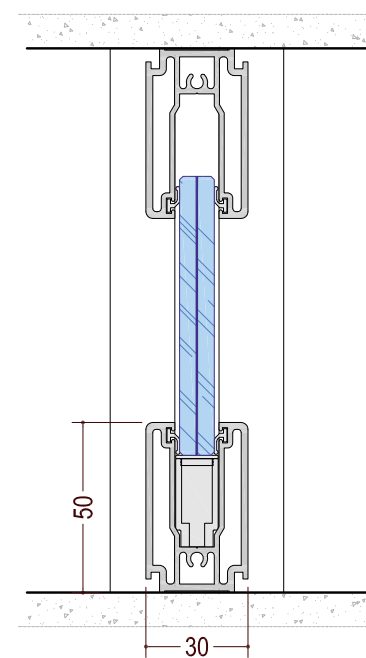

unica® u

Single glazed partition.
Acoustic performance:
from 32 to 35 dB.

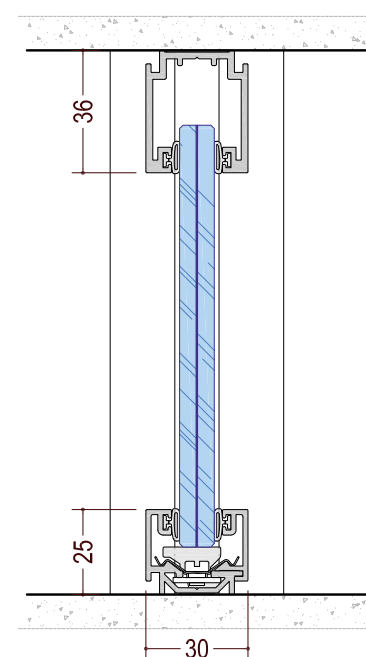

unica® slim

Single glazed partition.
Acoustic performance:
from 32 to 38 dB.

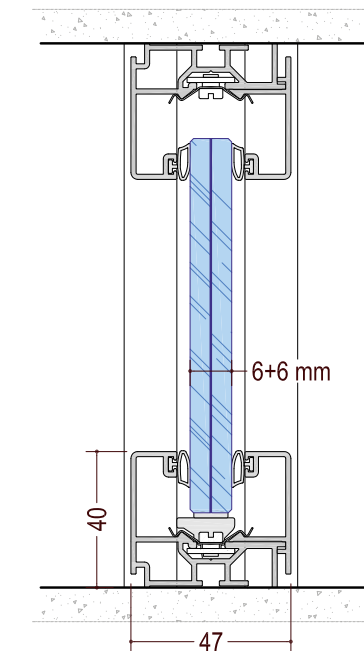

unica® sc

Single glazed partitions.
sc1 Acoustic performance:
from 36 to 38 dB.
sc2 Acoustic performance:
from 37 to 40 dB.
sc3 Acoustic performance:
from 32 to 35 dB.

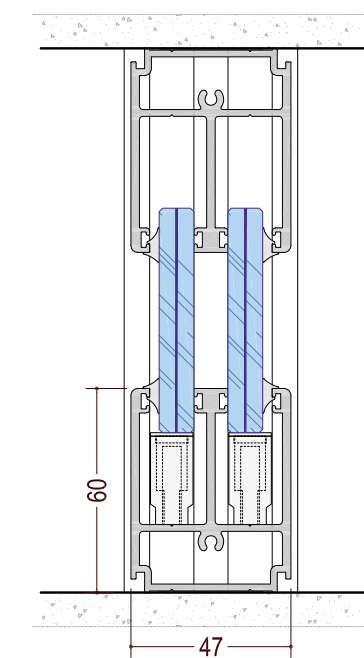

unica® d

Double glazed partition.
Acoustic performance:
from 37 to 39 dB.

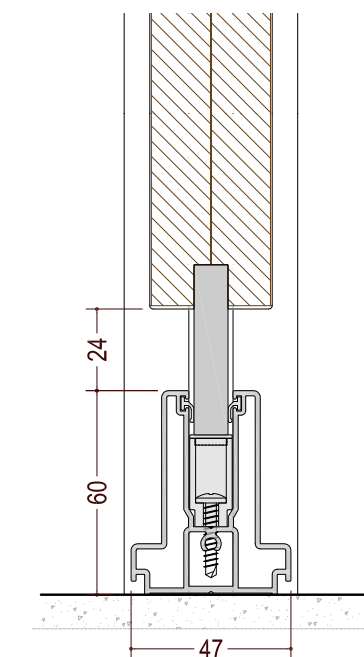

unica® solid

Solid partition.
Acoustic performance:
30 dB.

Single glazed partition.
T section profile.
5+5-mm thick laminated glass.
Acoustic performance: from 32 to 35 dB.

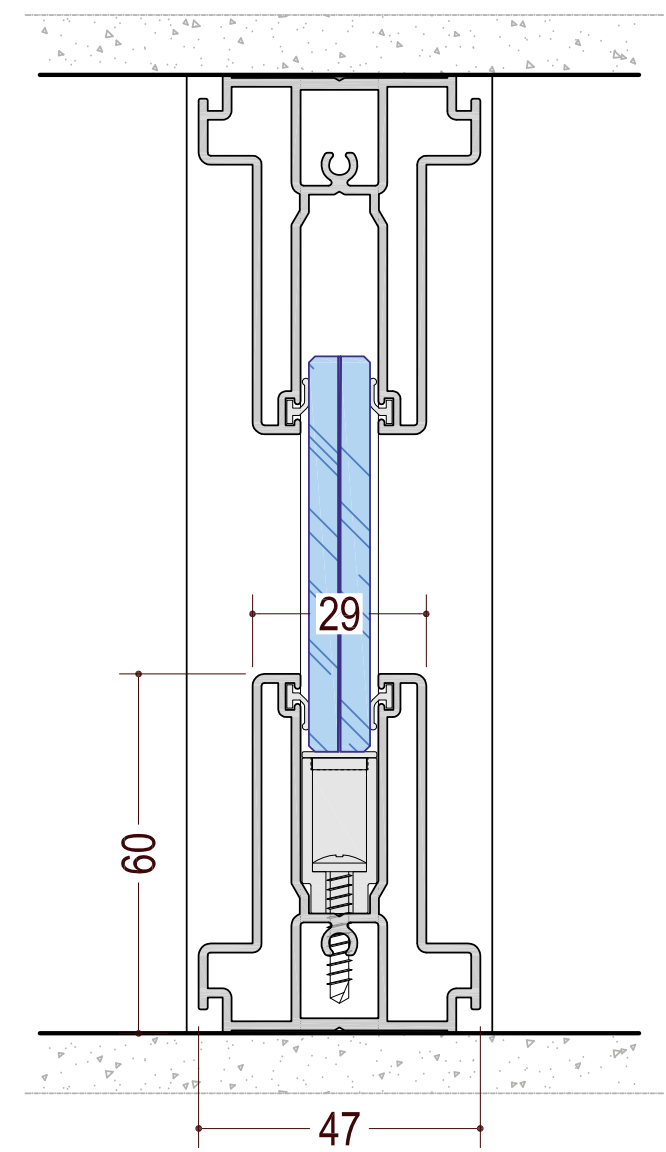
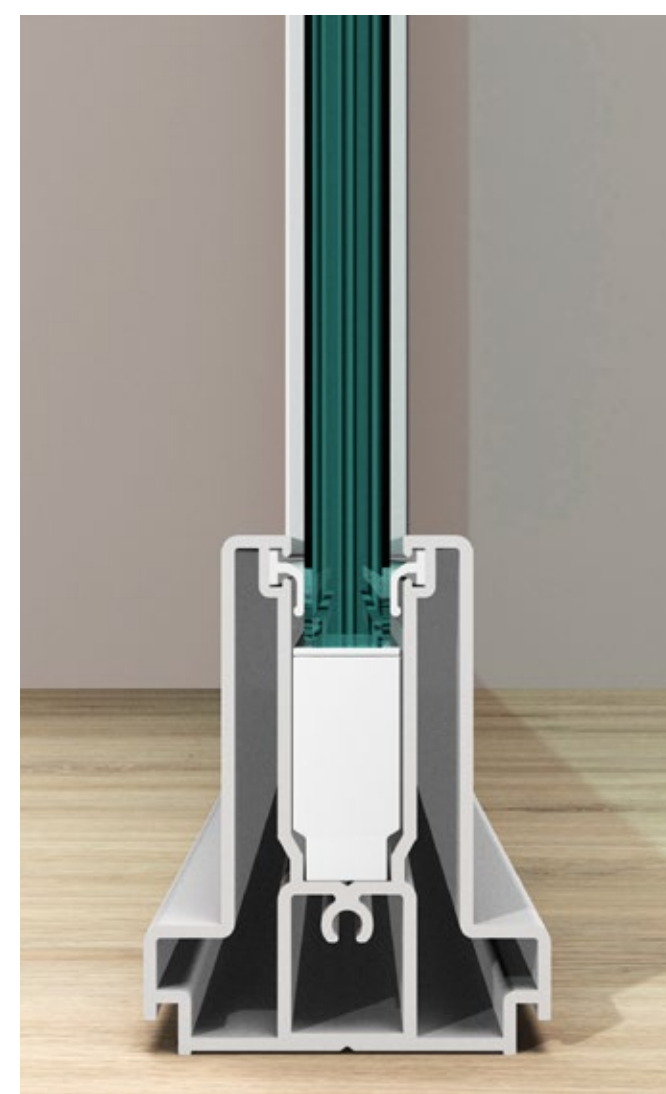

- unica® r**
unica® u
unica® slim
unica®
sc1/sc2/sc3
unica® d
unica® solid

unica® r
"T" section

Single glazed partition.
 U section profile.
 5+5-mm thick laminated glass.
 Acoustic performance: from 32 to 35 dB.

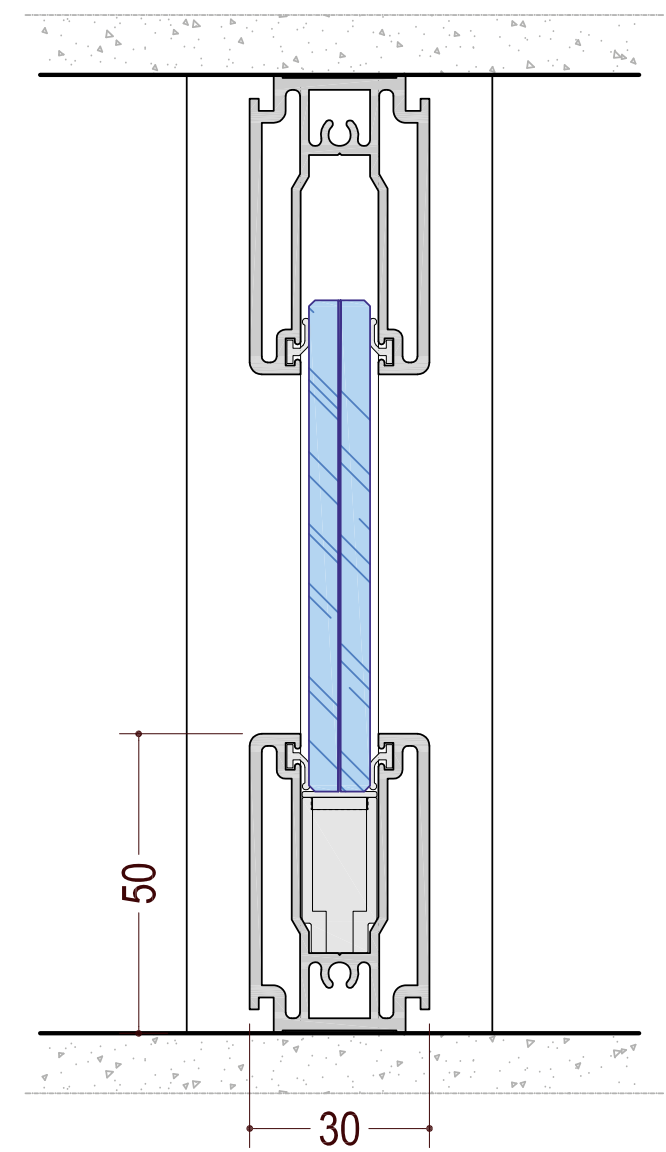

- unica® r
- unica® u**
- unica® slim
- unica® sc1/sc2/sc3
- unica® d
- unica® solid

unica® u
 "U" section

Single glazed partition.
 Thin section profile.
 5+5-mm or 6+6-mm thick laminated glass.
 Acoustic performance: from 32 to 38 dB.

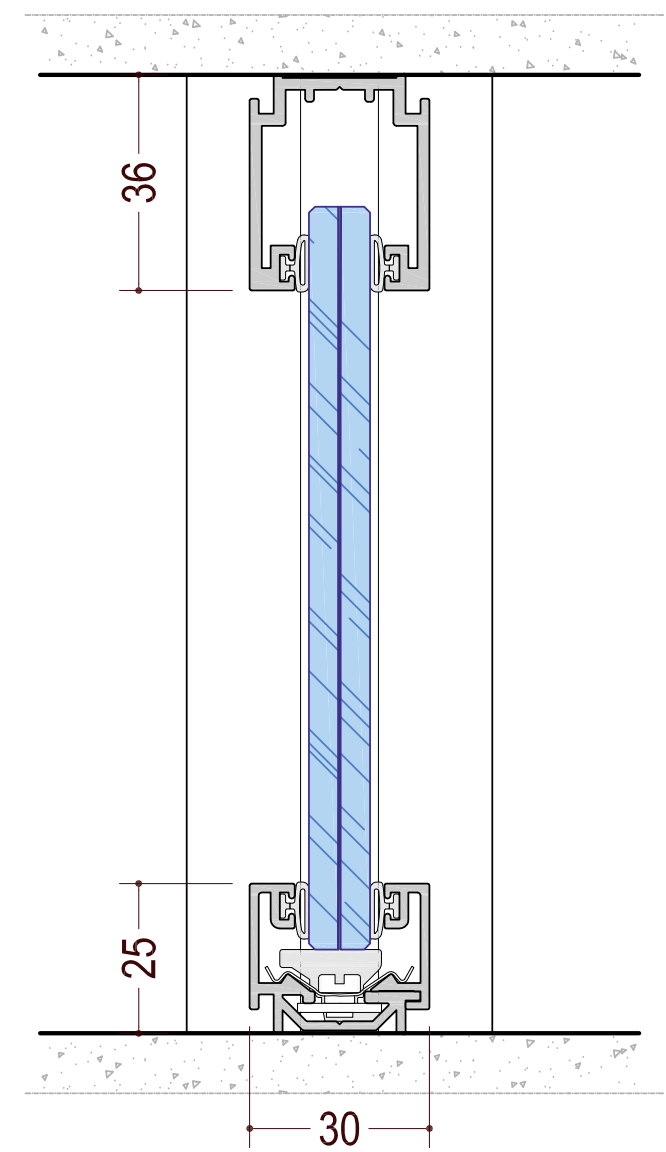
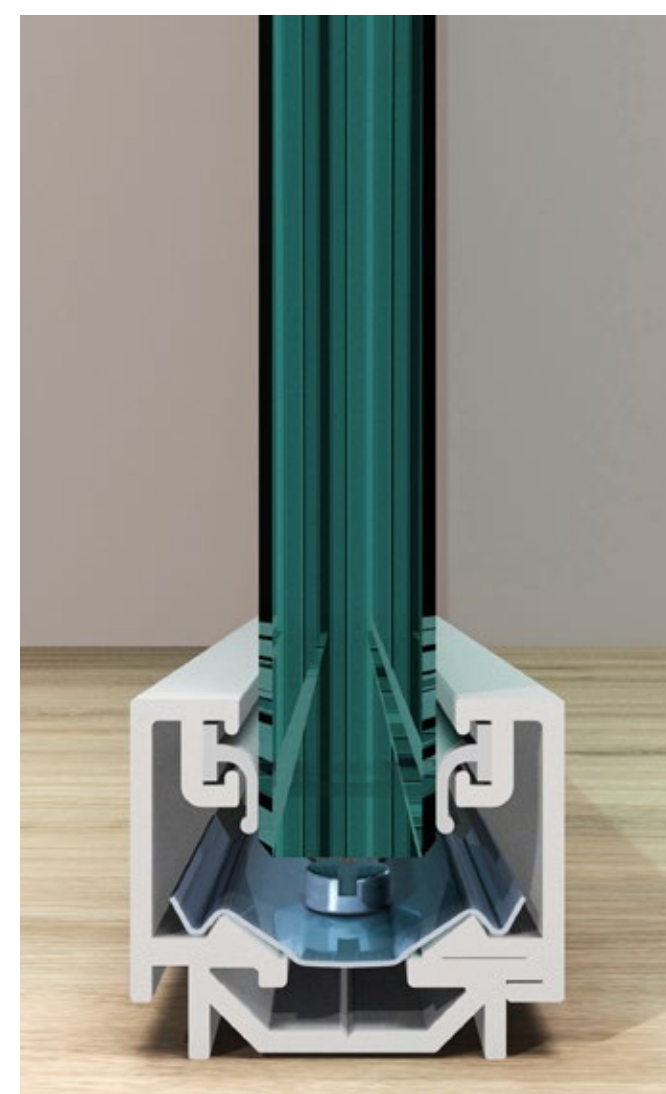

- unica® r
- unica® u
- unica® slim**
- unica® sc1/sc2/sc3
- unica® d
- unica® solid

unica® slim
 thin section

Single glazed partition.
 Rectangular section profile.
 6+6-mm thick laminated glass.
 Acoustic performance: from 36 to 38 dB.

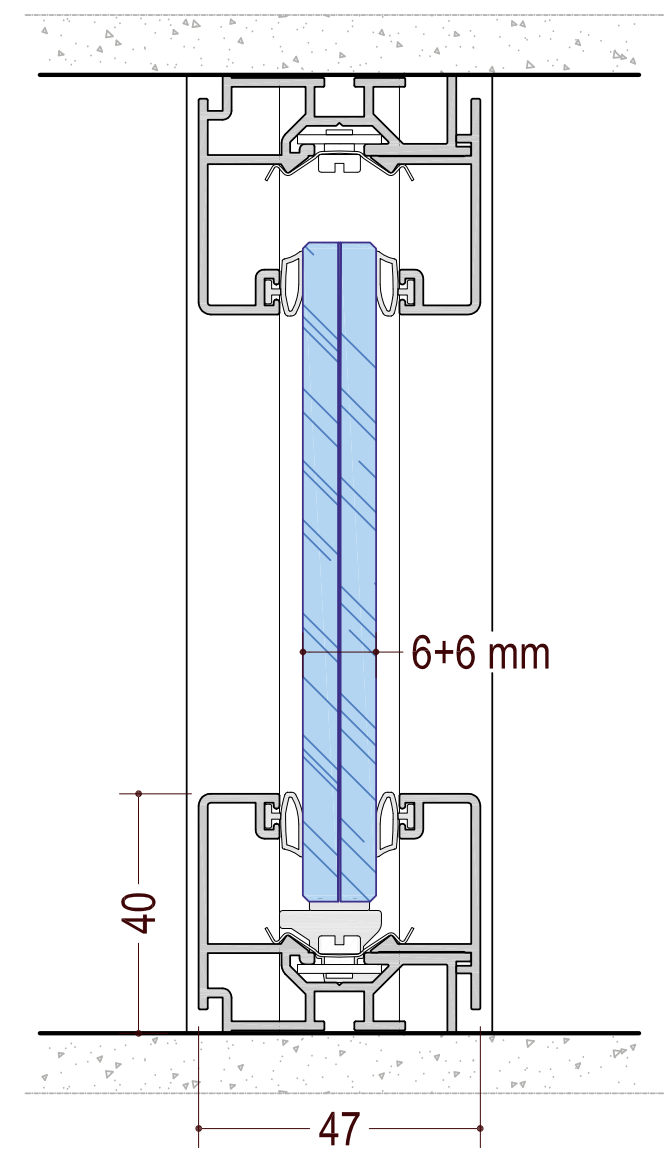
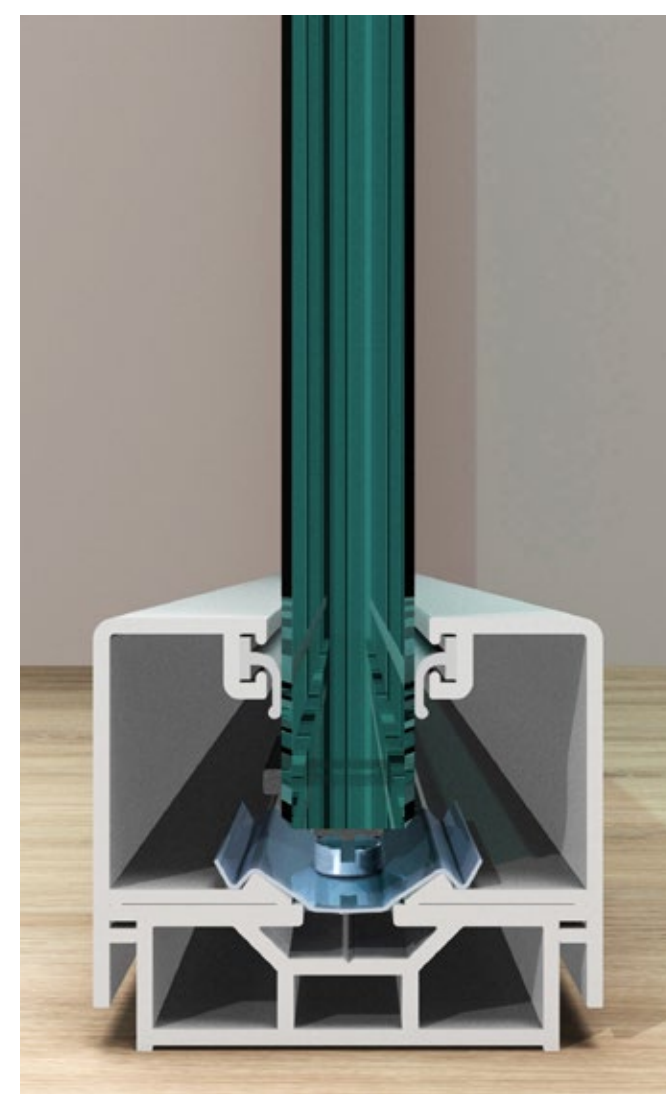

- unica® r
- unica® u
- unica® slim
- unica®**
sc1/sc2/sc3
- unica® d
- unica® solid

unica® sc1
 rectangular section



Single glazed partition.
Rectangular section profile.
8+8-mm thick laminated glass.
Acoustic performance: from 37 to 40 dB.

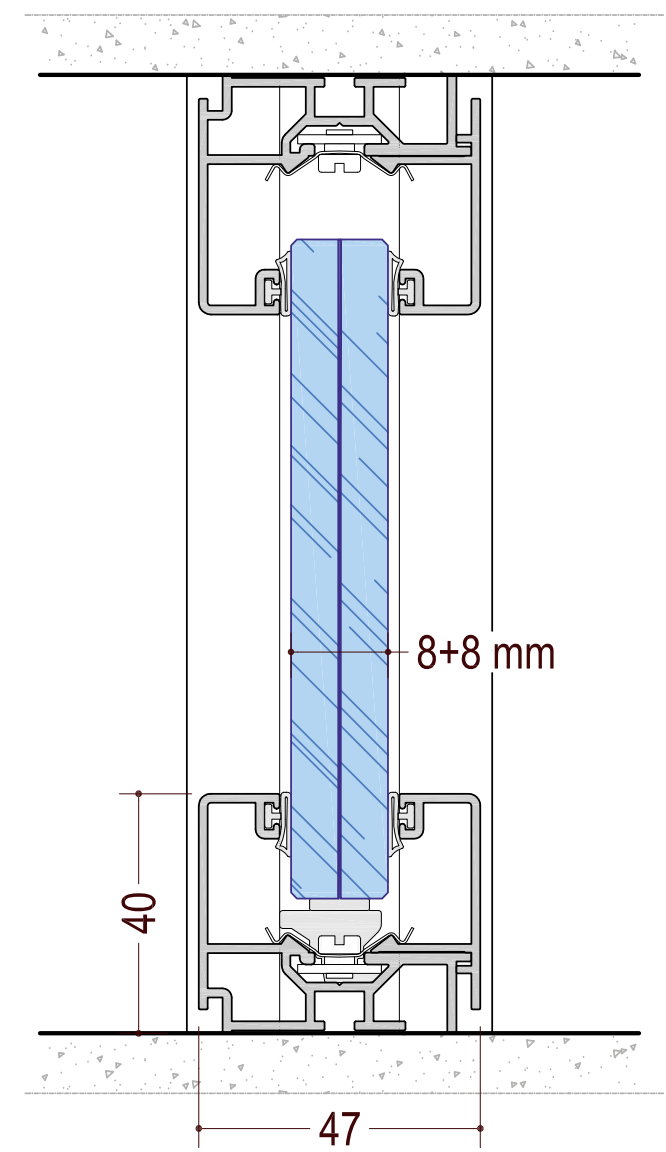

- unica® r
- unica® u
- unica® slim
- unica®**
sc1/**sc2**/sc3
- unica® d
- unica® solid

unica® sc2

rectangular section



Single glazed partition.
 Rectangular section profile.
 5+5-mm thick laminated glass.
 Acoustic performance: from 32 to 35 dB.

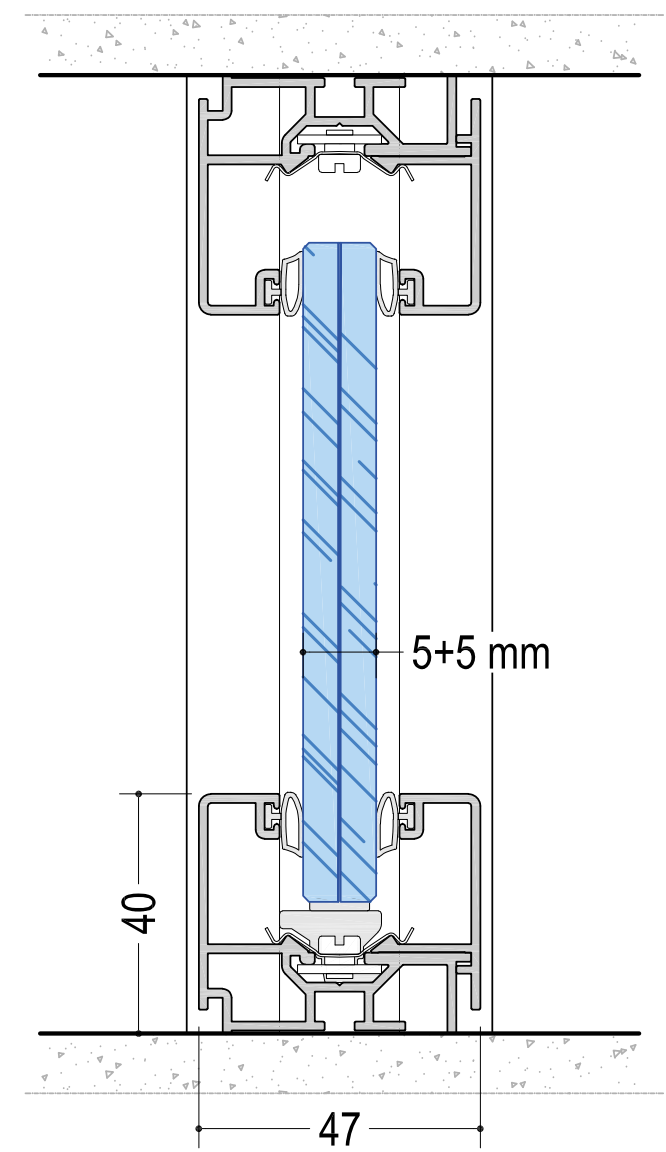
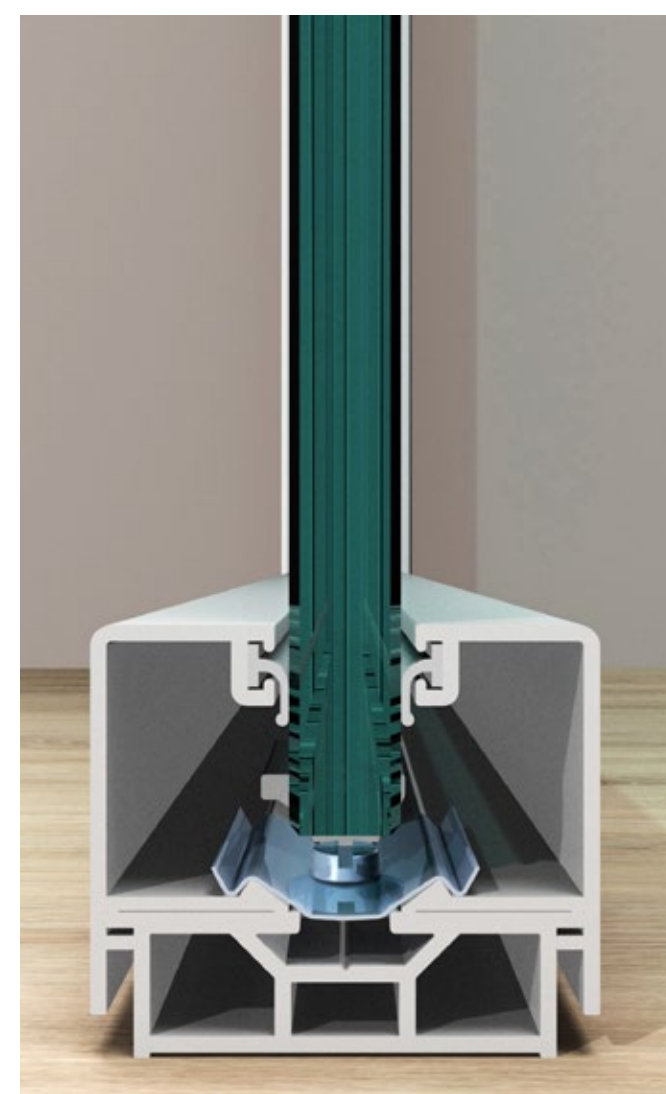

- unica® r
- unica® u
- unica® slim
- unica®**
sc1/sc2/**sc3**
- unica® d
- unica® solid

unica® sc3
 rectangular section



Double glazed partition.
 "U" section profile.
 5+5-mm thick laminated double glass.
 Acoustic performance: from 37 to 39 dB.

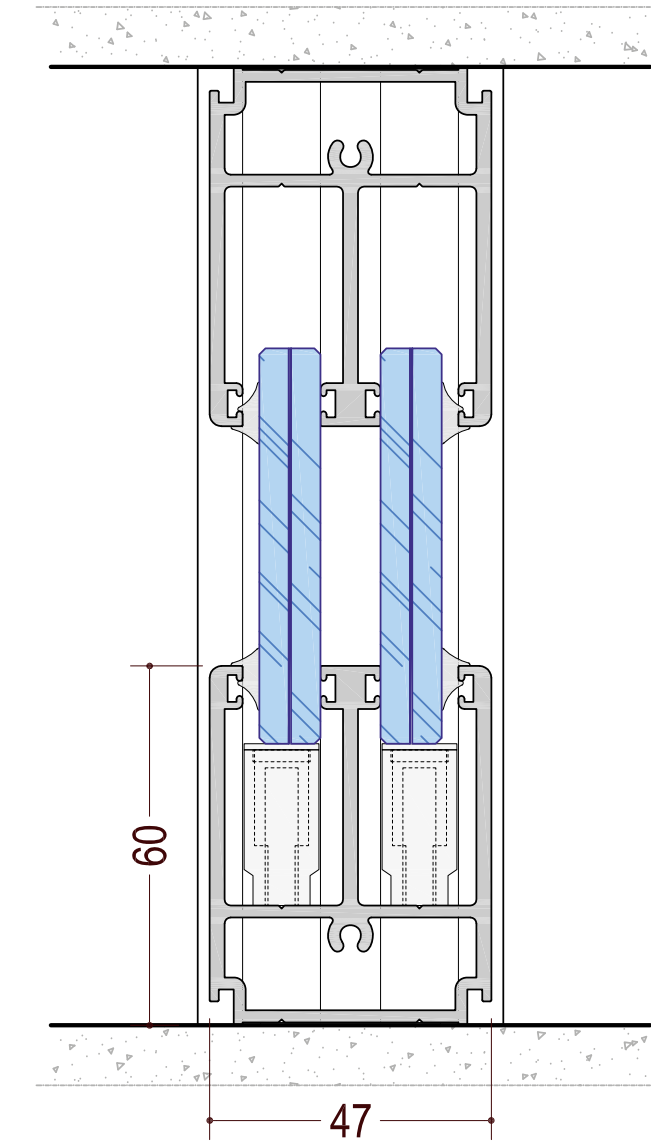
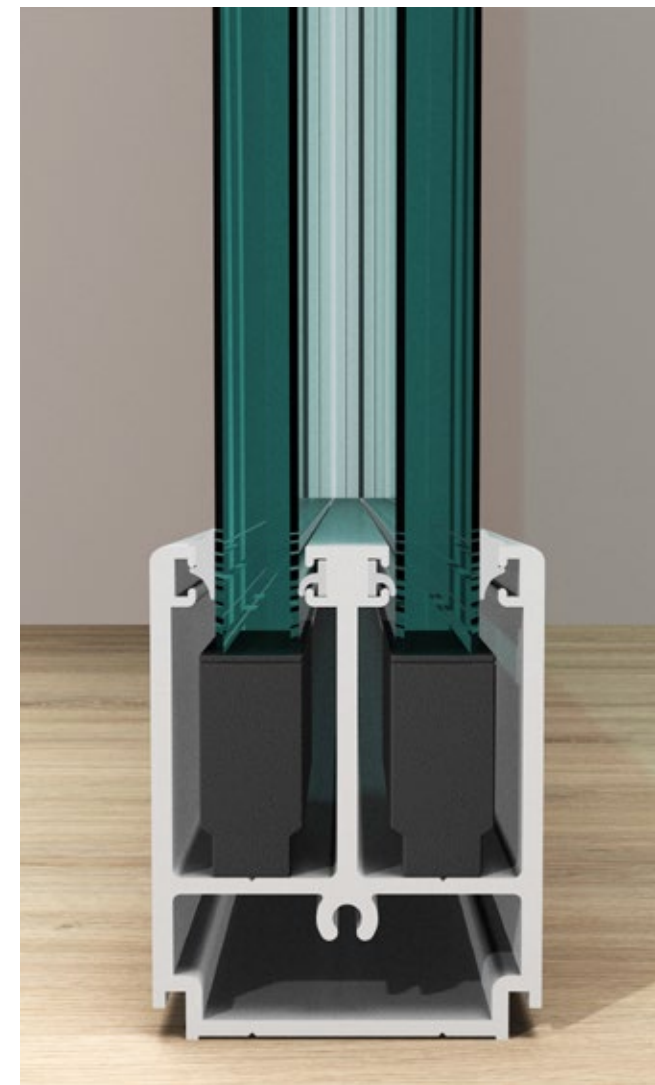

- unica® r
- unica® u
- unica® slim
- unica® sc1/sc2/sc3
- unica® d**
- unica® solid

unica® d
 "U" section – double glass



Solid partition.
 Available on all Unica profiles, r, u, slim, sc.
 36-mm thick melamine-faced chipboard panel.
 Acoustic performance 30 dB.

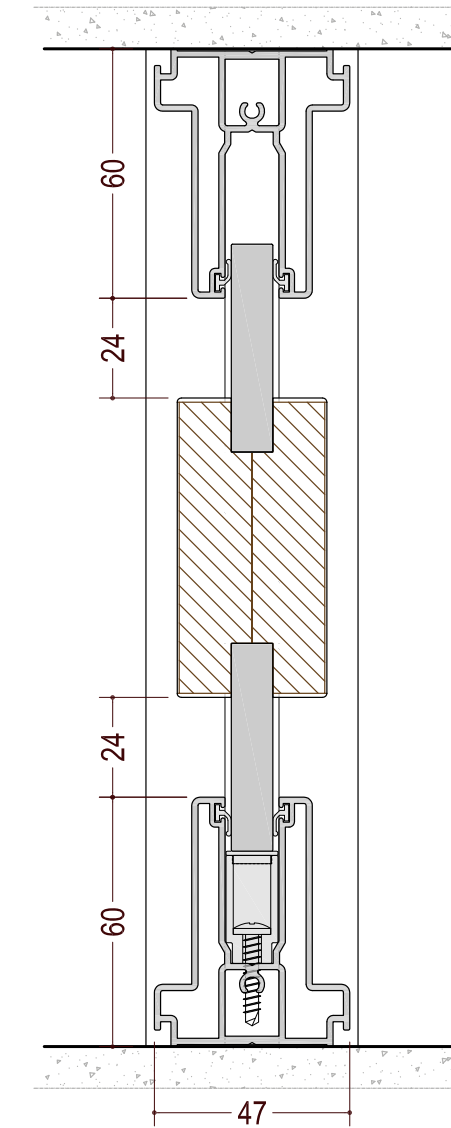

unica® solid

36-mm. thick solid panel

- unica® r
- unica® u
- unica® slim
- unica® sc1/sc2/sc3
- unica® d
- unica® solid**



ritmica[®] aluminium

70-mm thick Partition Wall
(single glass, double glass, solid)

Ritmica is a range of 70-mm thick partition walls, offering many solutions and having the possibility to use filling panels, solid or glazed, the latter with central or asymmetrical panels.

ETOILE

lafano
oltre l'ufficio

ETOILE

lafano
oltre l'ufficio

ritmica® aluminium

70-mm thick
Partition Wall

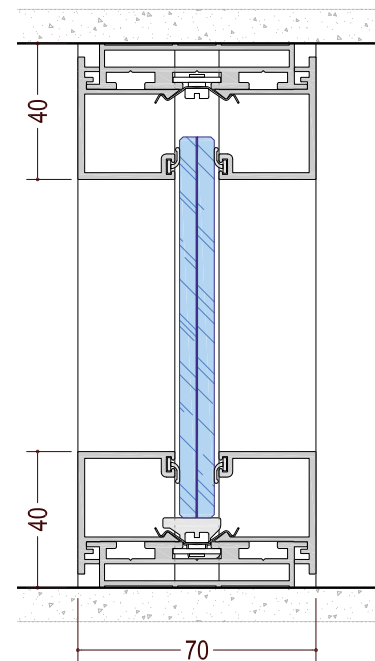

ritmica® d1

Central glass partition.
Acoustic performance:
from 34 to 38 dB.

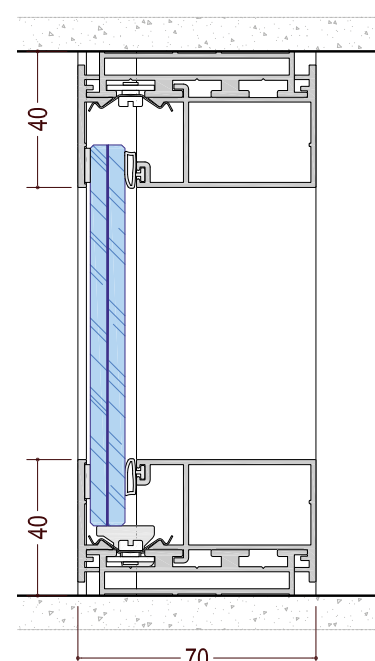

ritmica® dA

Asymmetrical glass partition.
Acoustic performance:
from 34 to 38 dB.

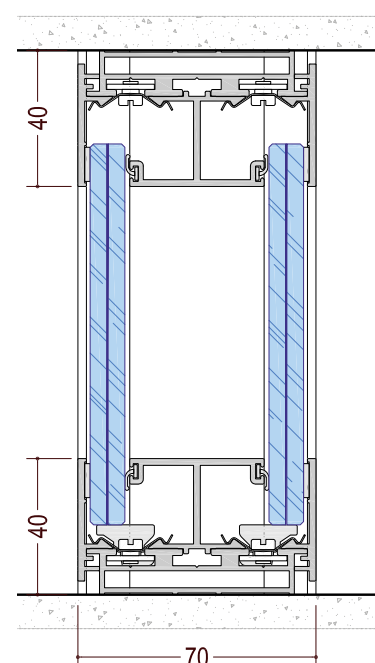

ritmica® d2

Double glazed partition.
Acoustic performance:
from 38 to 43 dB.

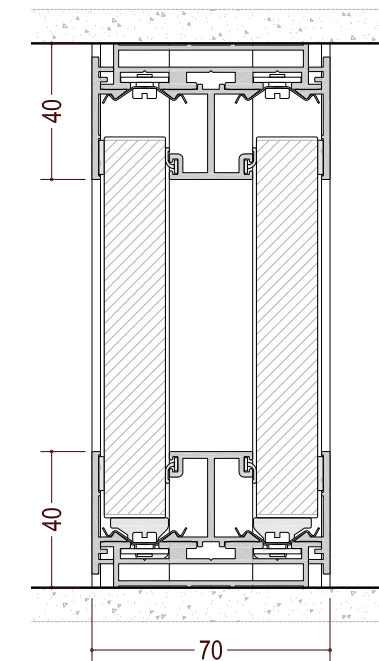

ritmica® solid

Solid partition.
Acoustic performance:
39 dB.

Central glass partition.
 5+5-mm or 6+6-mm thick laminated glass.
 Acoustic performance: from 34 to 38 dB.

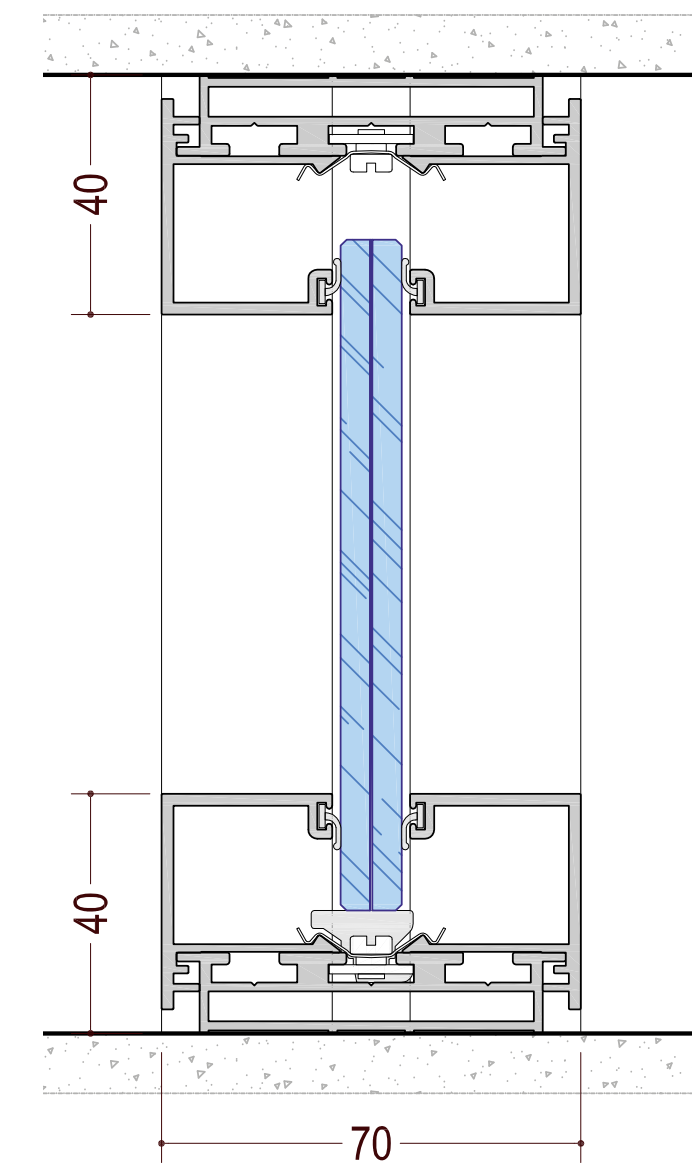

ritmica® d1
 central glass

- ritmica® d1**
- ritmica® dA
- ritmica® d2
- ritmica® solid

Asymmetrical glass partition.
 5+5-mm or 6+6-mm thick laminated glass.
 Acoustic performance: from 34 to 38 dB.

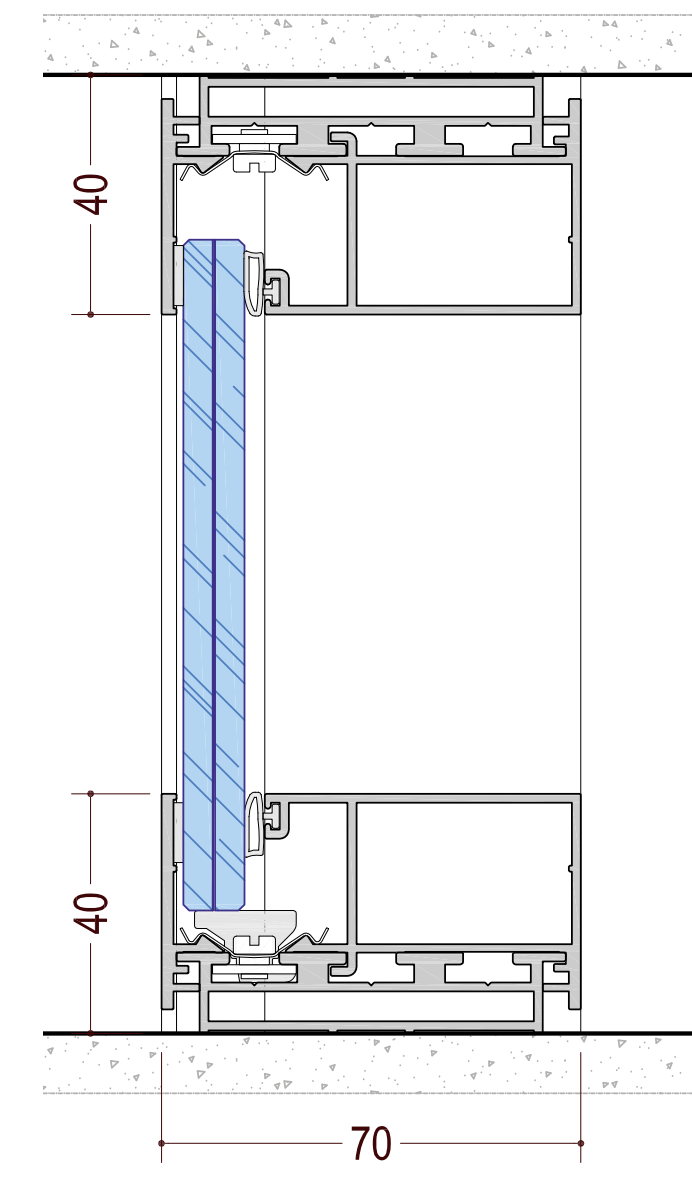

ritmica® d1
ritmica® dA
 ritmica® d2
 ritmica® solid

ritmica® dA
 asymmetrical glass

Double glass partition.
 5+5-mm or 6+6-mm thick laminated glass.
 Acoustic performance: from 38 to 43 dB.

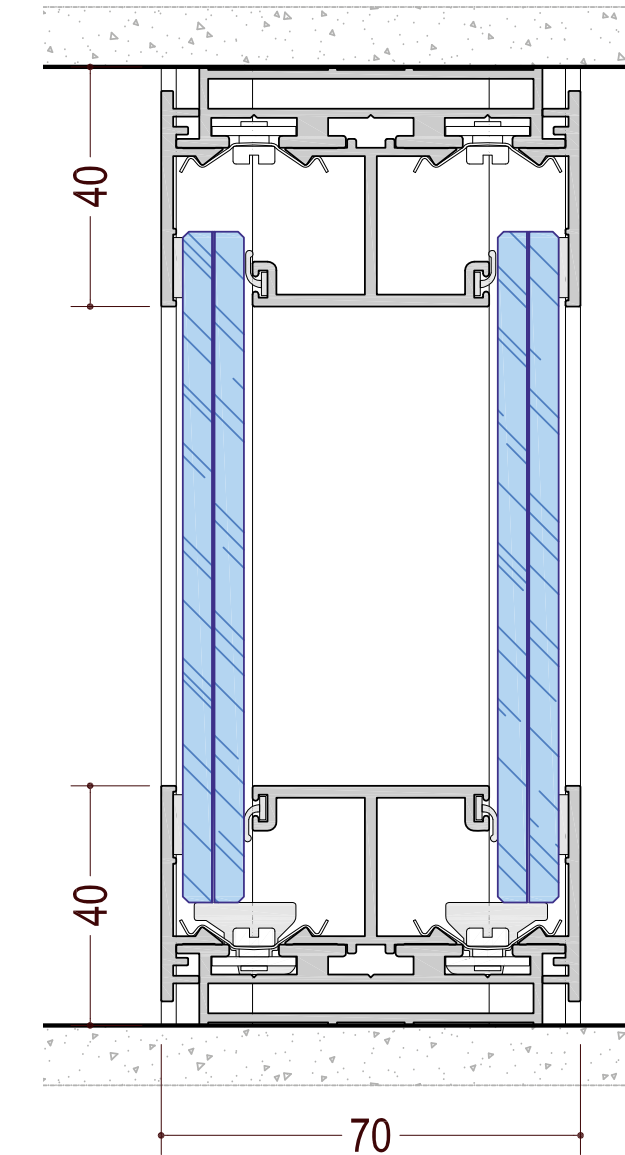
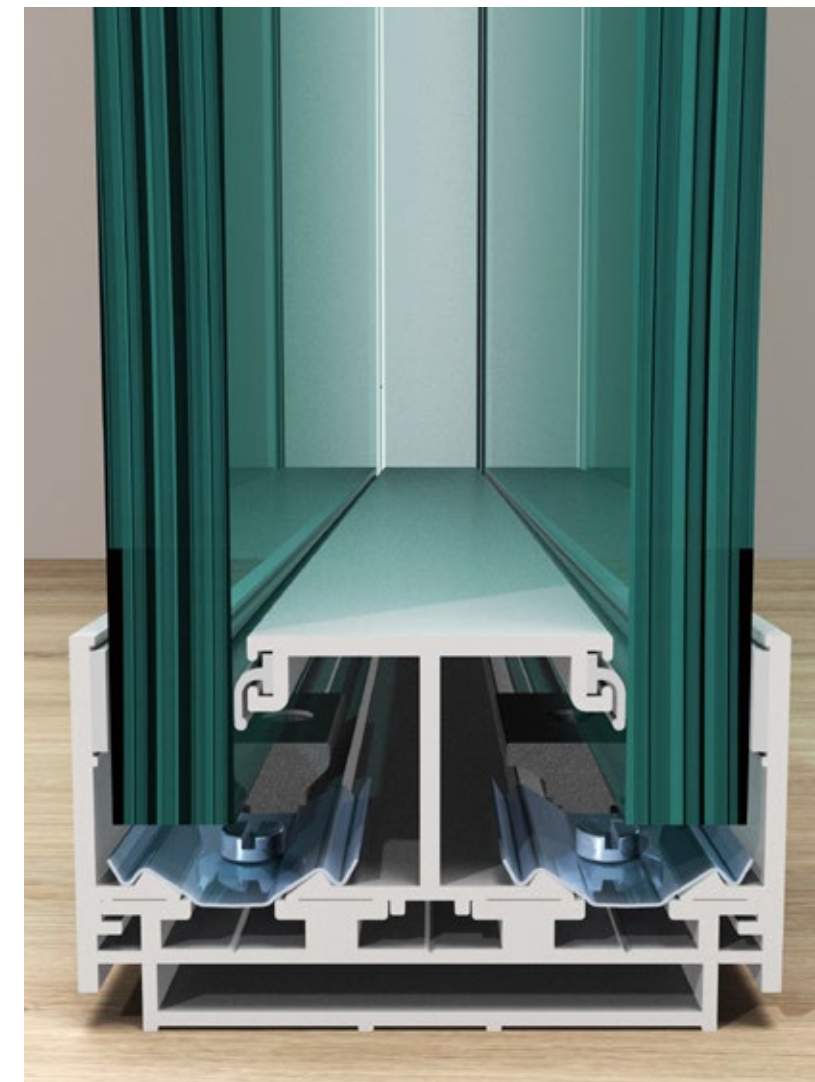

ritmica® d1
 ritmica® dA
ritmica® d2
 ritmica® solid

ritmica® d2
 double glass

Solid partition.
 18-mm thick solid double panel.
 Acoustic performance: 39 dB.

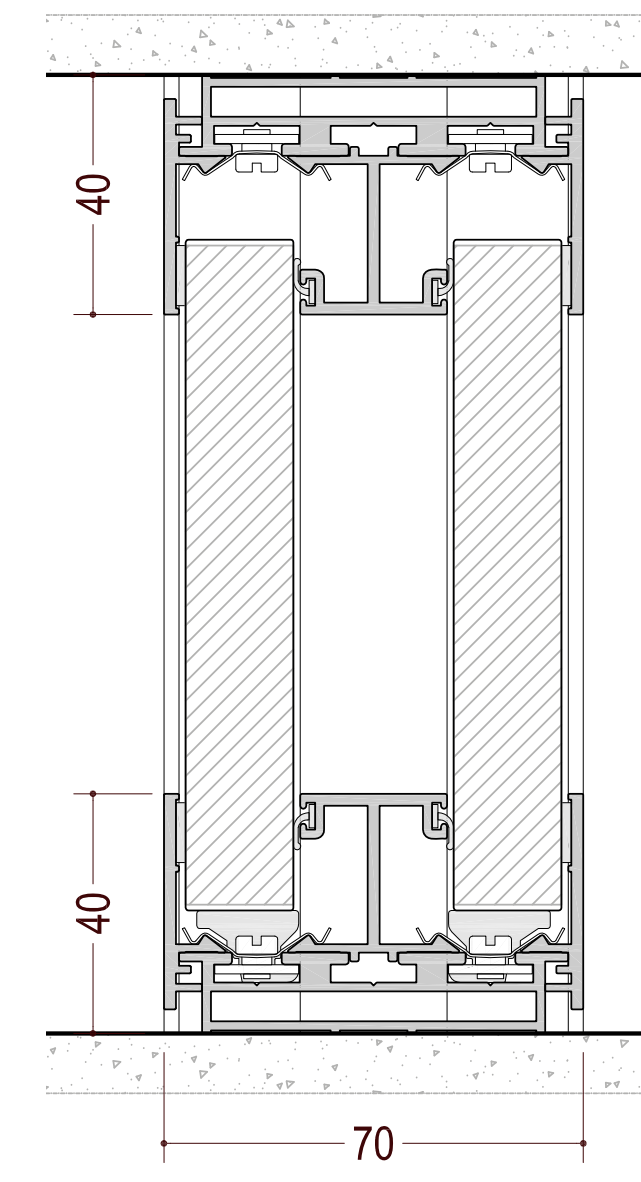

ritmica® d1
 ritmica® dA
 ritmica® d2
ritmica® solid

ritmica® solid
 18-mm thick solid double panel



ritmica[®] wood

92-mm thick Partition Wall
(single glass, double glass, solid)

Ritmica wood is an innovative line of partition walls taking its name from the wooden veneered profiles.

Rediscovering tradition while looking to the future is the philosophy behind Ritmica Wood, perfect for elegant spaces while offering optimum acoustics.

ETOILE

lafano
oltre l'ufficio



ritmica®
wood
92-mm thick
Partition Wall

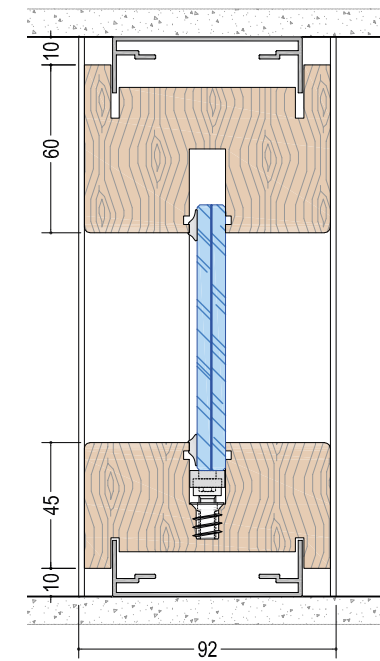

ritmica® wood d1
Central glass partition.

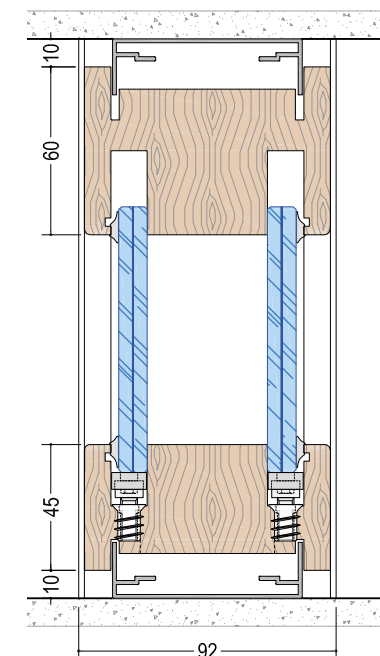

ritmica® wood d2
Double glazed partition.

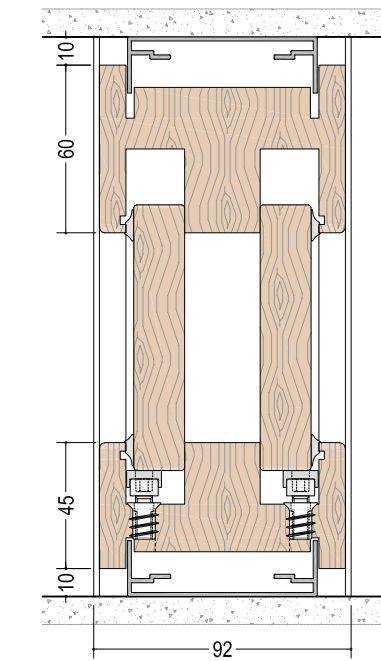

ritmica® wood solid
Double 18-mm thick
solid partition.

Central glass partition.
 5+5-mm thick laminated glass.

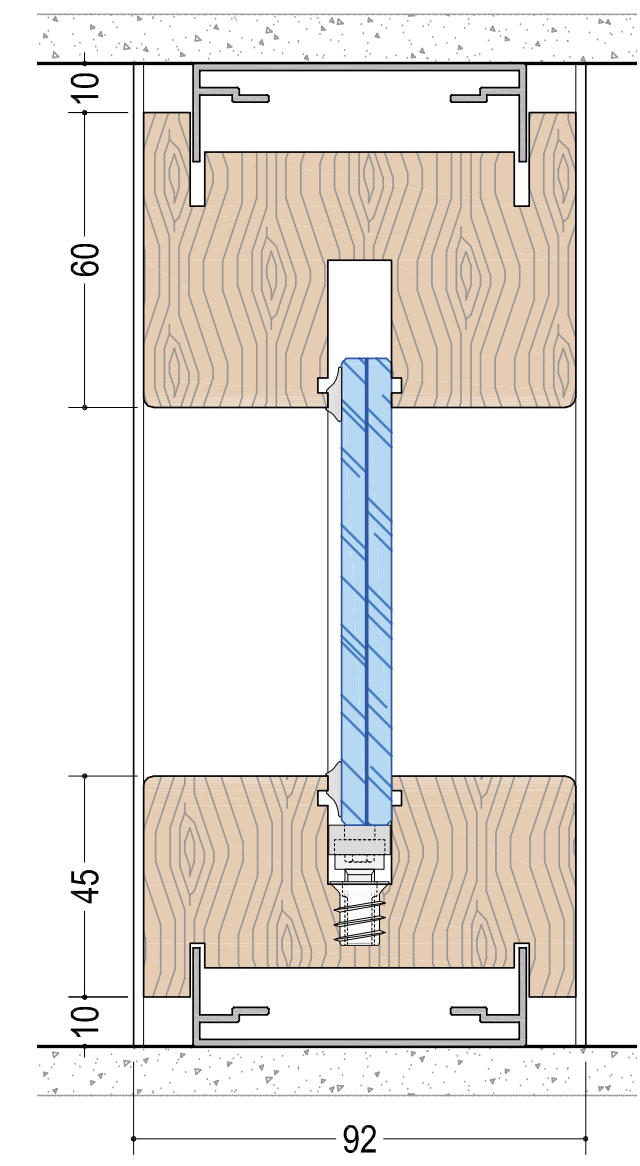

ritmica® wood d1
 ritmica® wood d2
 ritmica® wood solid

ritmica® wood d1
 central glass

Double glazed partition.
 5+5-mm thick laminated glass.

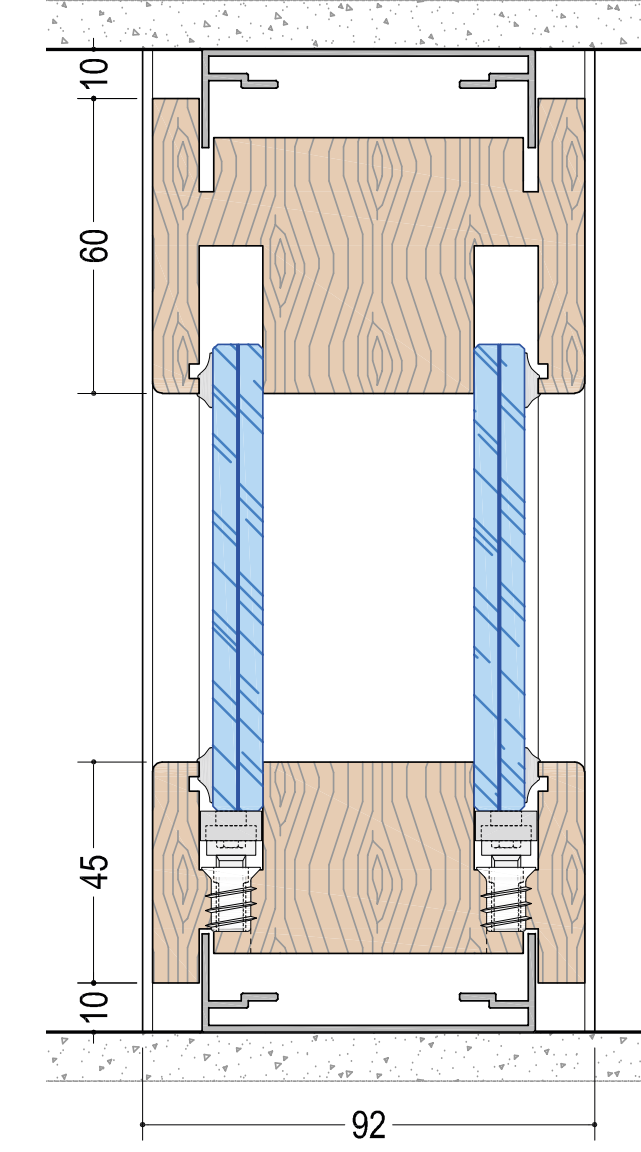

ritmica®
 wood d1
**ritmica®
 wood d2**
 ritmica®
 wood solid

ritmica® wood d2
 double glass

Solid partition.
18-mm thick double solid panel.

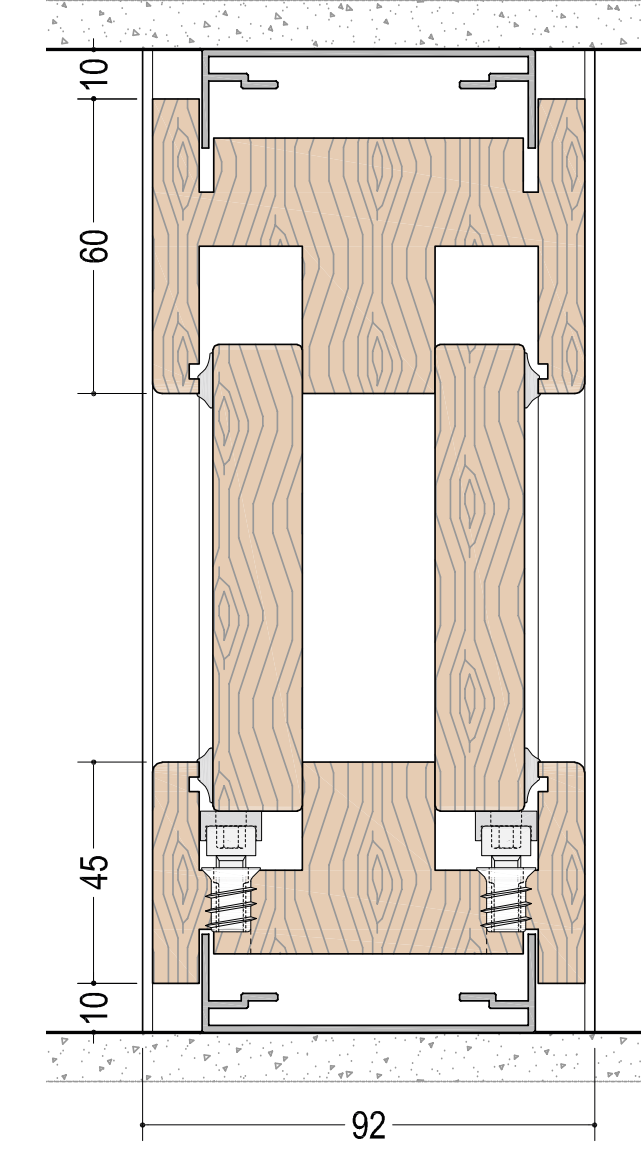

ritmica®
wood d1
ritmica®
wood d2
**ritmica®
wood solid**

ritmica® wood solid

18-mm thick double solid partition



metrica[®] structural

104-mm thick Partition Wall
(single glass, double glass, solid)

Metrica is a range of 104-mm thick partition walls, offering many solutions and having the possibility to use filling panels, whether solid or glazed.

Metal supporting structure, with both vertical and horizontal development.

ETOILE

lafano
oltre l'ufficio



ETOILE

lafano
oltre l'ufficio

metrica® structural

104-mm thick
Partition Wall

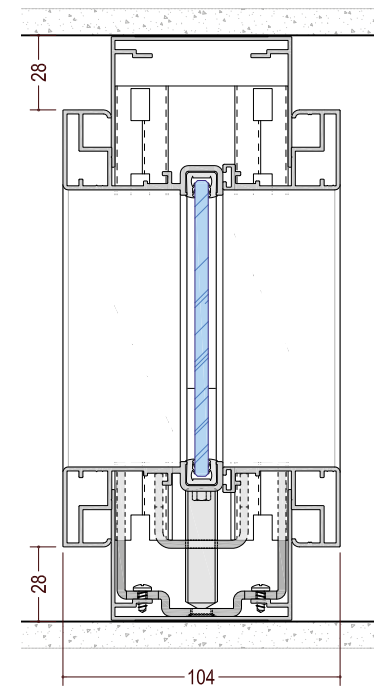

metrica® r

Central glass partition.
Acoustic performance:
from 30 to 38 dB

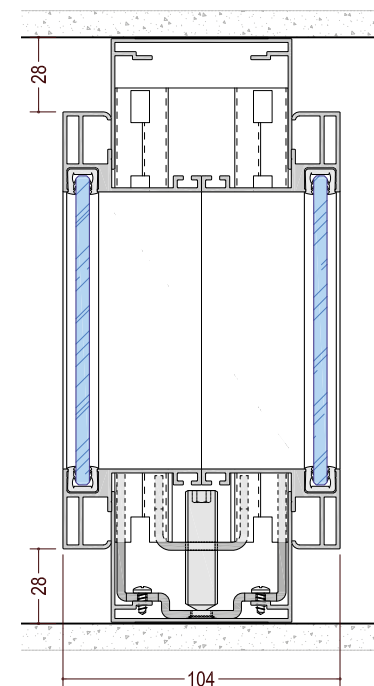

metrica® v

Double glazed framed
partition.
Acoustic performance:
from 40 to 47 dB.

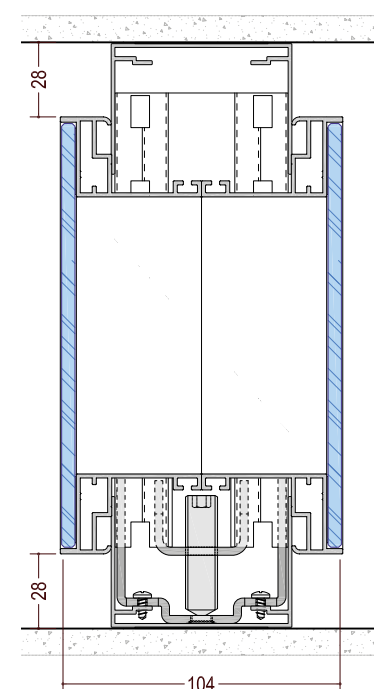

metrica® s

External-flush double
glazed partition.
Acoustic performance:
from 38 to 44 dB.

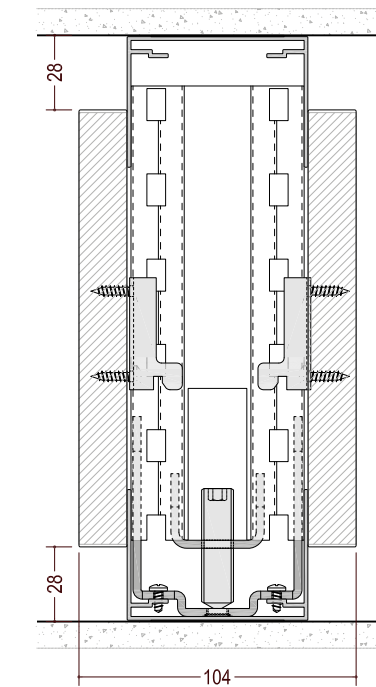

metrica® solid

Double 18-mm thick
solid partition.
Acoustic performance:
from 37 to 46 db.

Central glass partition.
Squared profile.
5-mm thick tempered glass.
Acoustic performance: from 30 to 38 dB.

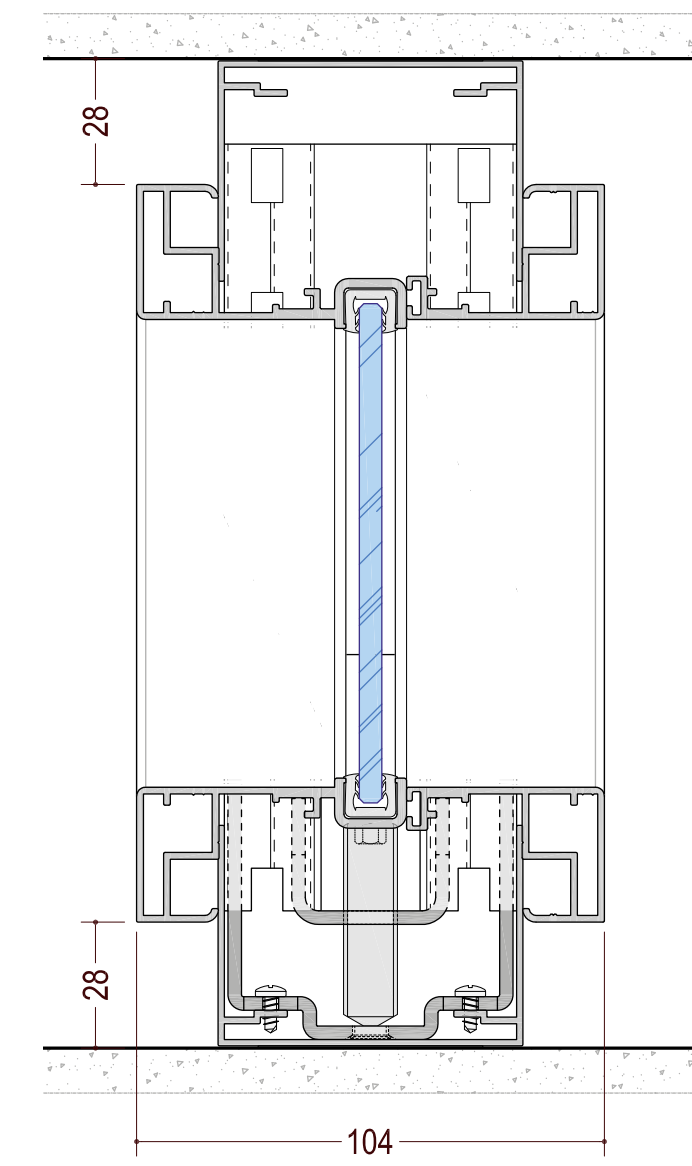

metrica® r
squared profile

metrica® r
metrica® v
metrica® s
metrica® solid



Framed, double glazed partition.
Squared profile.
3+3-mm thick laminated glass.
Acoustic performance: from 40 to 47 dB.

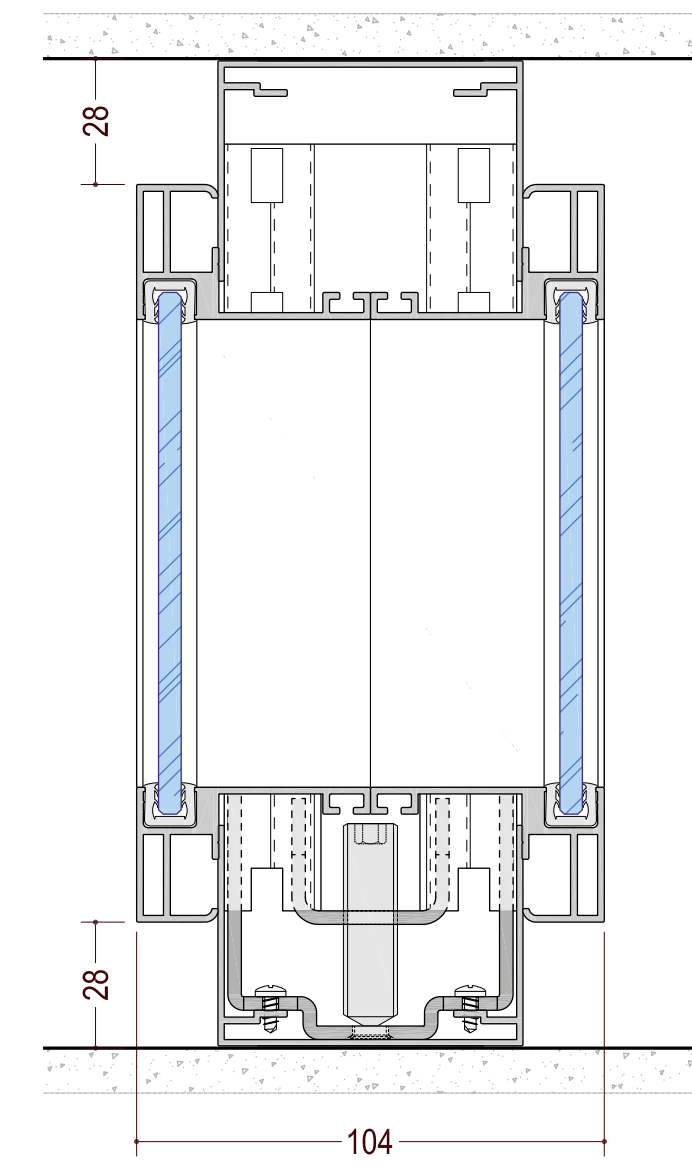

metrica® v
double framed glass

metrica® r
metrica® v
metrica® s
metrica® solid

Flush double glazed partition,
 external etched band.
 5-mm thick tempered double glass.
 Acoustic performance: from 38 to 44 dB.

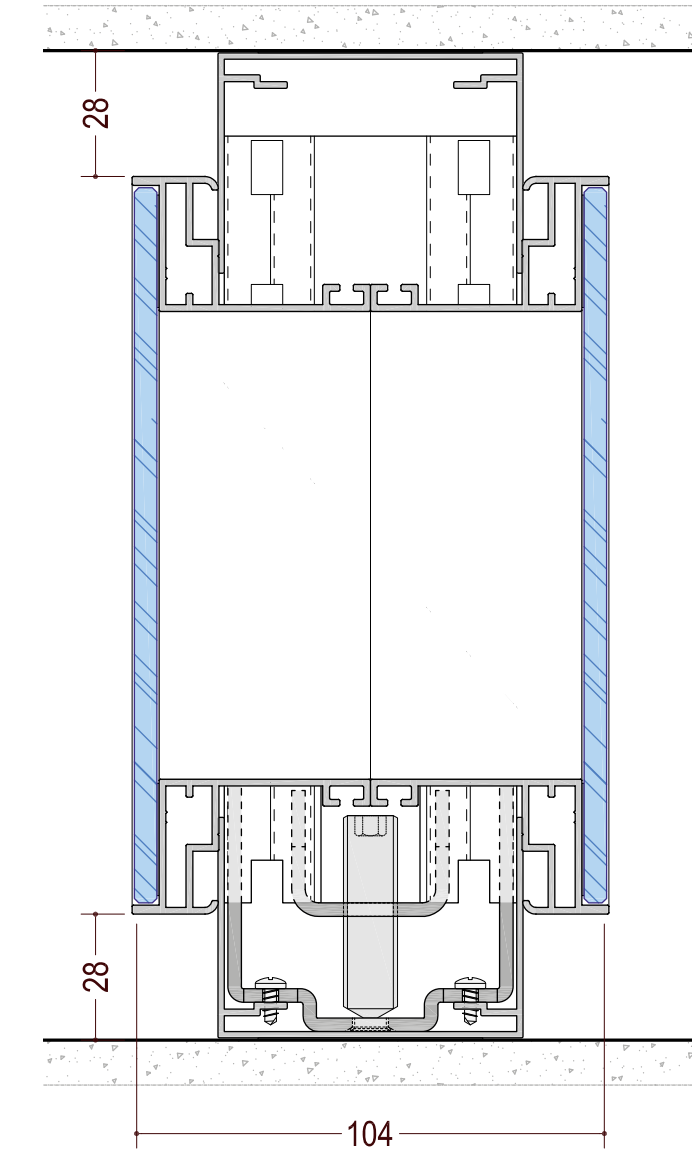
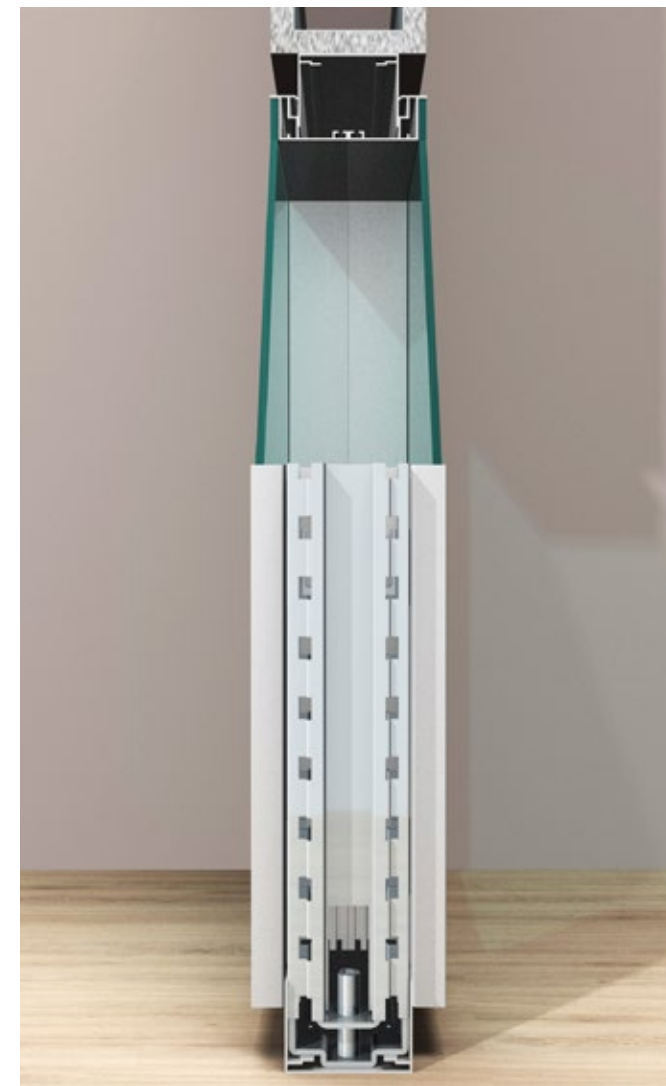

metrica® r
 metrica® v
metrica® s
 metrica® solid

metrica® s
 flush double glazed partition

Partition wall with double solid panel.
 18-mm thick double solid panel.
 Acoustic rate: from 37 to 46 dB.

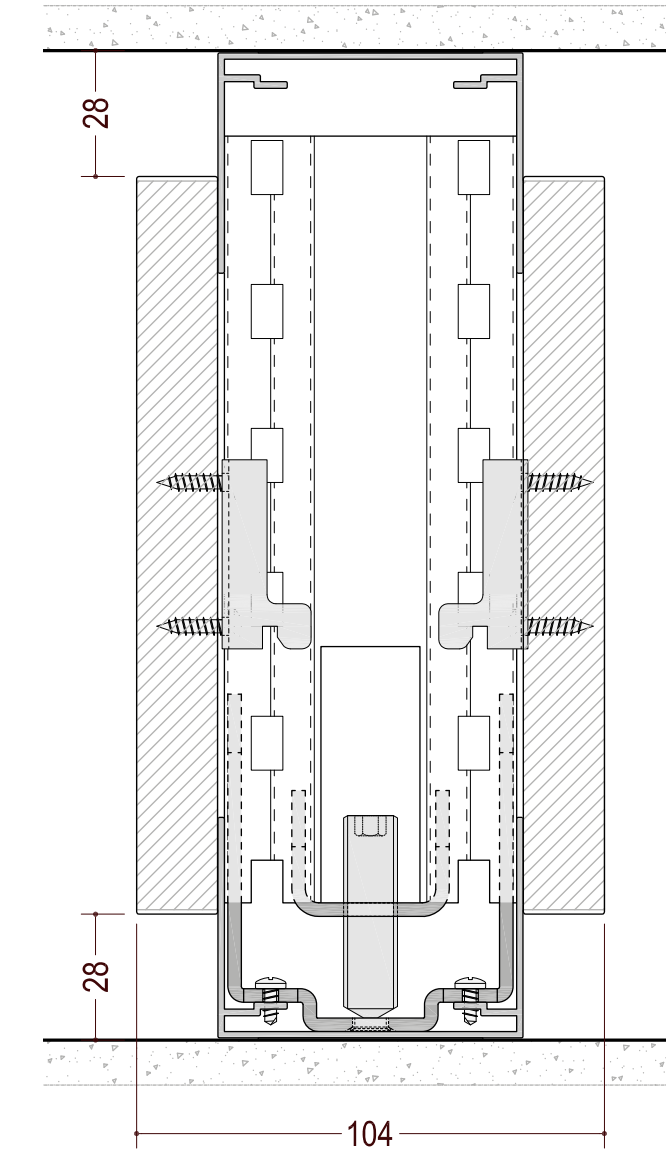

metrica® r
 metrica® v
 metrica® s
metrica® solid

metrica® solid
 18-mm thick double solid panel



metrica[®] frameless

104-mm thick Partition Wall
(single glass, double glass, solid)

A new generation of acoustic glass walls, with high sound insulation. Designed with single or double glass, it stands out for the absence of structural uprights.

The search for total transparency has led to the design of fully glazed corners, made of glass-to-glass junctions.

ETOILE

lafano
oltre l'ufficio



ETOILE

lafano
oltre l'ufficio

metrica®
frameless
104-mm thick
Partition Wall

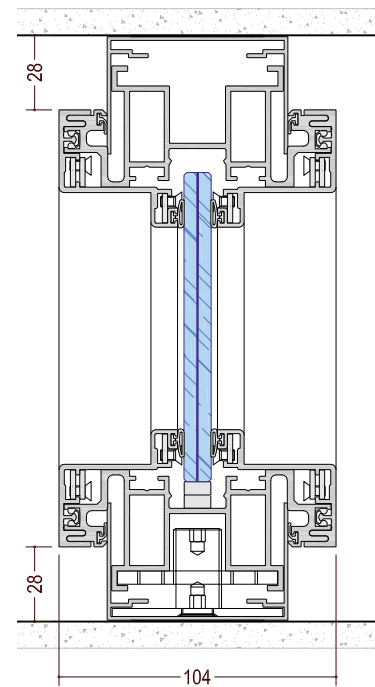

metrica® d1
Central glass partition.

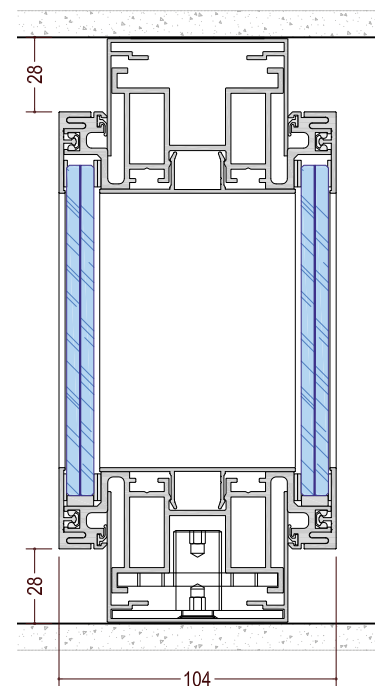

metrica® d2
Double glazed partition.
Acoustic performance:
from 39 to 47 dB.

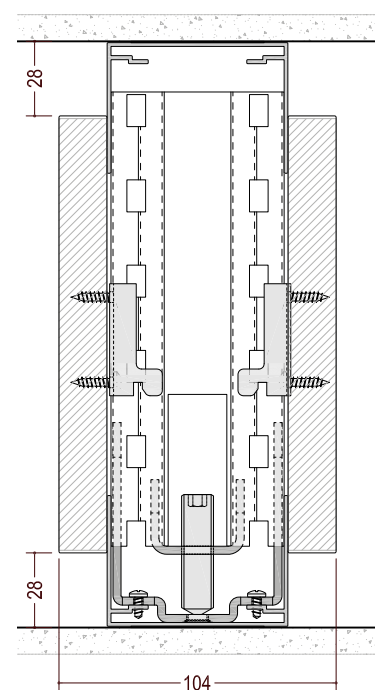

metrica® solid
Double 18-mm thick
solid partition.
Acoustic performance:
from 37 to 46 db.

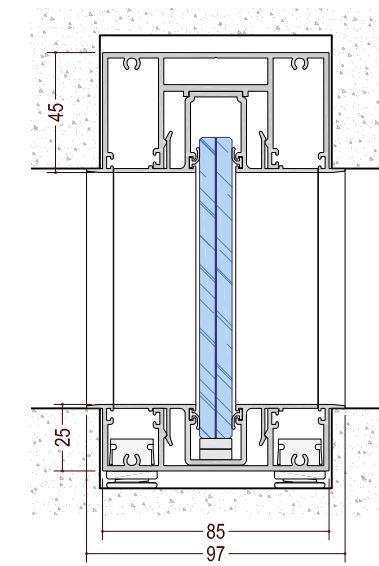

metrica® f1
Central glass partition.
Concealed profile.

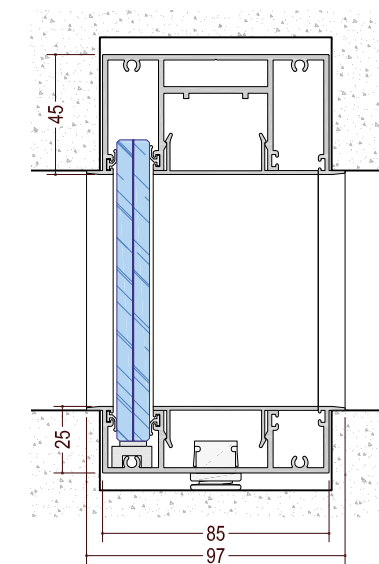

metrica® fA
Asymmetrical glazed
partition.
Concealed profile.

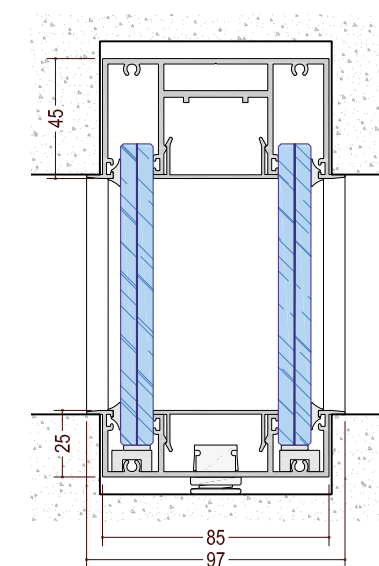

metrica® f2
Double glazed partition.
Concealed profile.

Central glass.
 6+6-mm thick laminated single glass.

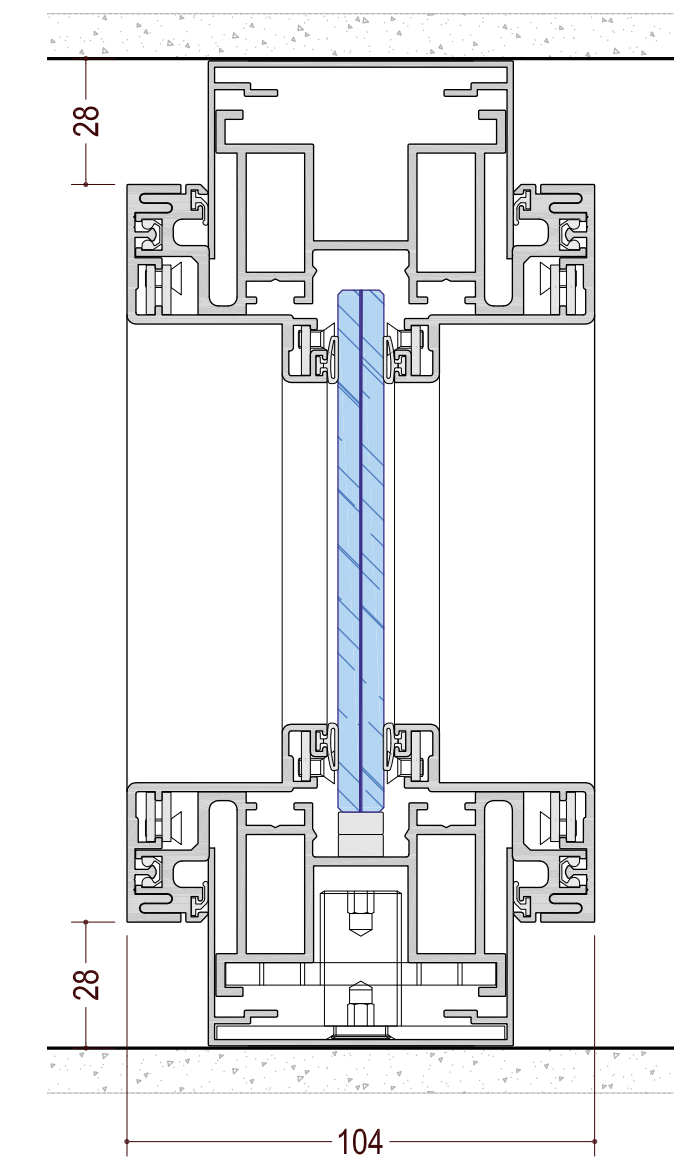

- metrica® d1**
- metrica® d2
- metrica® solid
- metrica® f1
- metrica® fA
- metrica® f2

metrica® d1
 central glass

Double glazed partition.
 5+5-mm or 6+6-mm thick laminated double glass.
 Acoustic rate: from 39 to 43 dB.

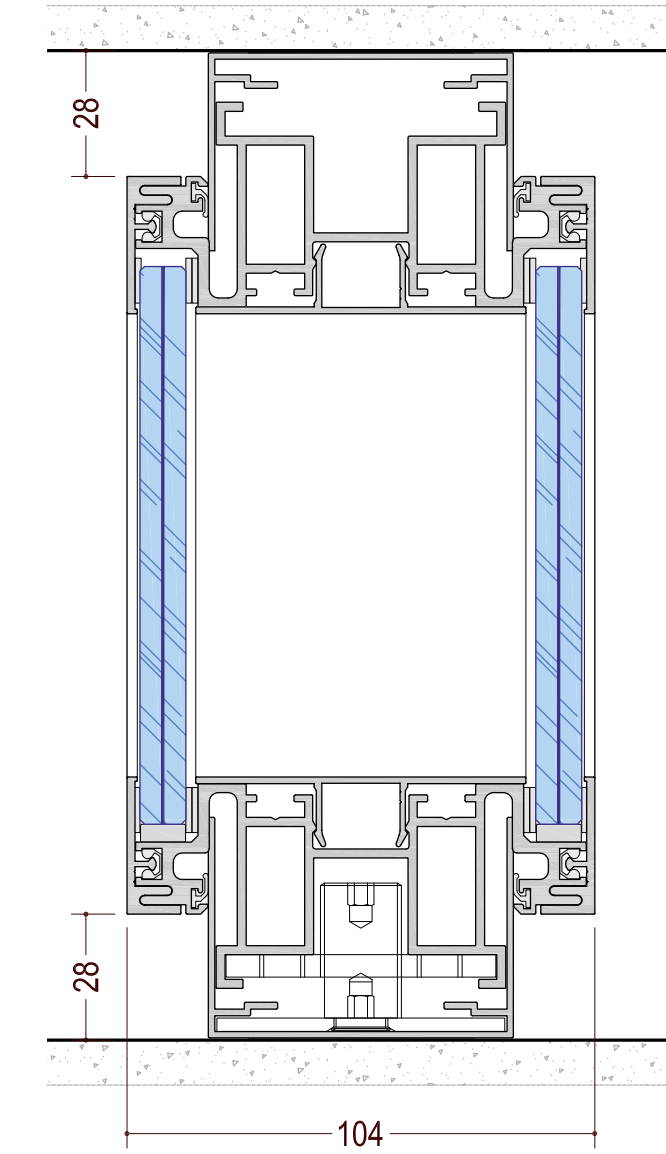

- metrica® d1
- metrica® d2**
- metrica® solid
- metrica® f1
- metrica® fA
- metrica® f2

metrica® d2
 double glass

Partition wall with double solid panel.
 18-mm thick double solid panel.
 Acoustic rate: from 37 to 46 dB.

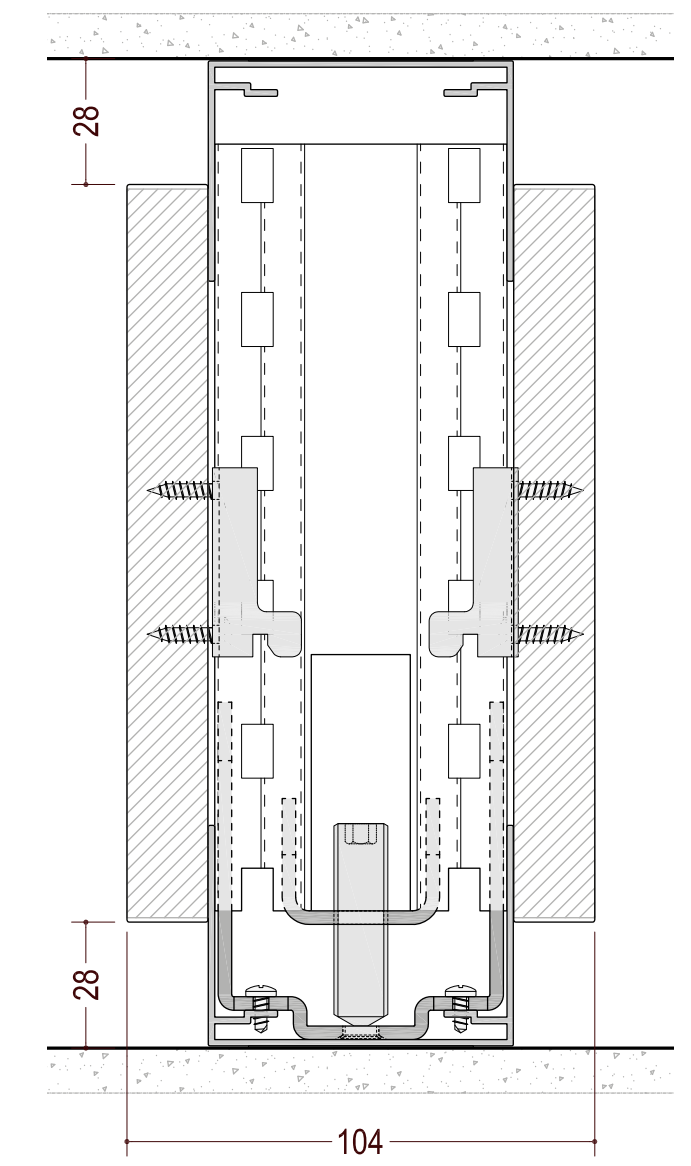

- metrica® d1
- metrica® d2
- metrica® solid**
- metrica® f1
- metrica® fA
- metrica® f2

metrica® solid

18-mm thick double solid panel

Central glass partition.
 Concealed profile.
 5+5-mm or 6+6-mm thick laminated single glass.

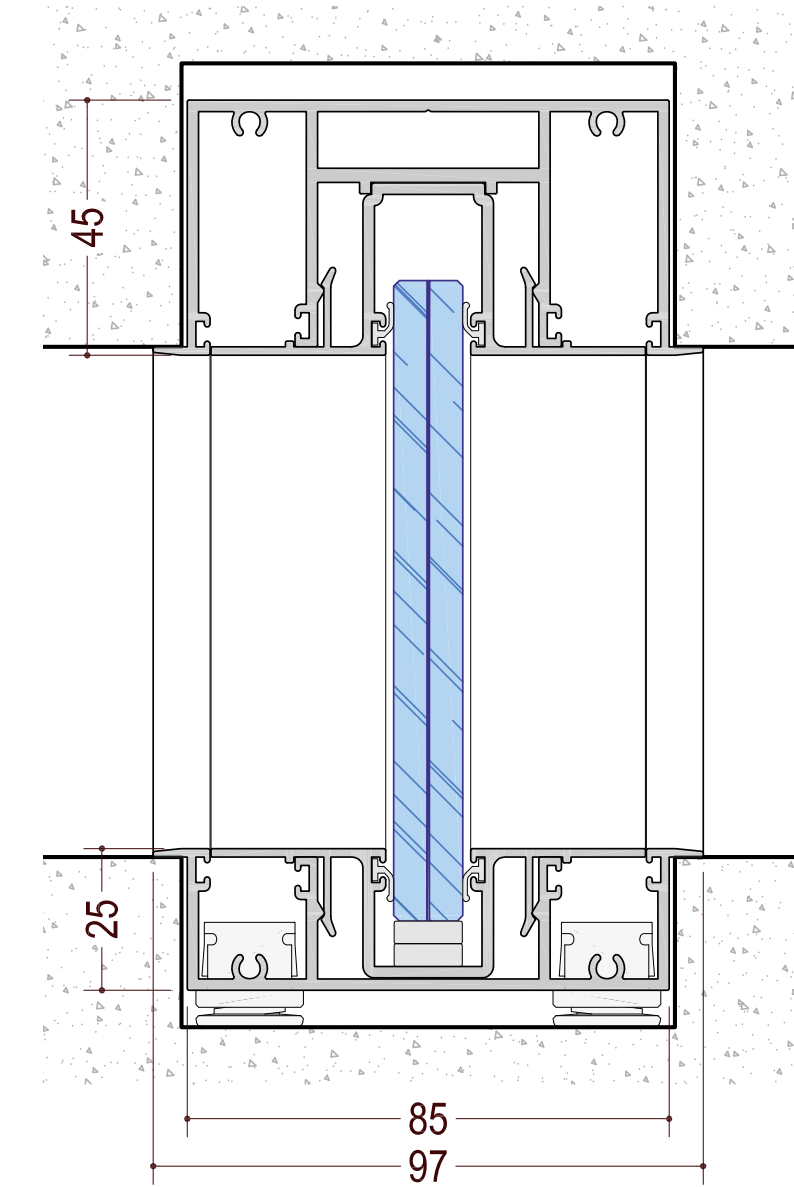
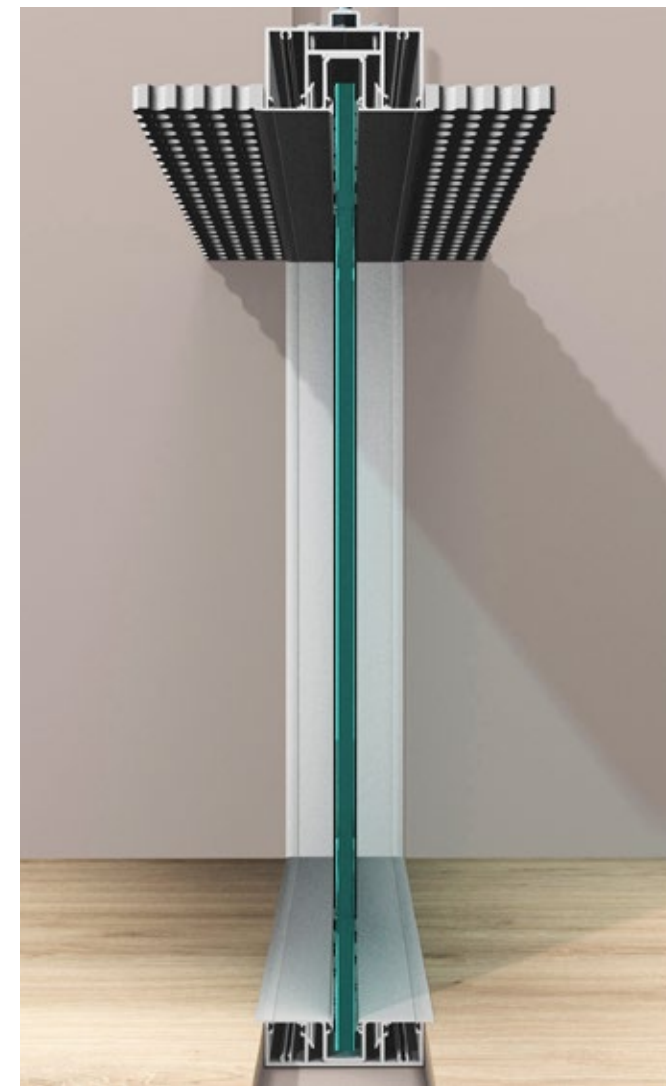
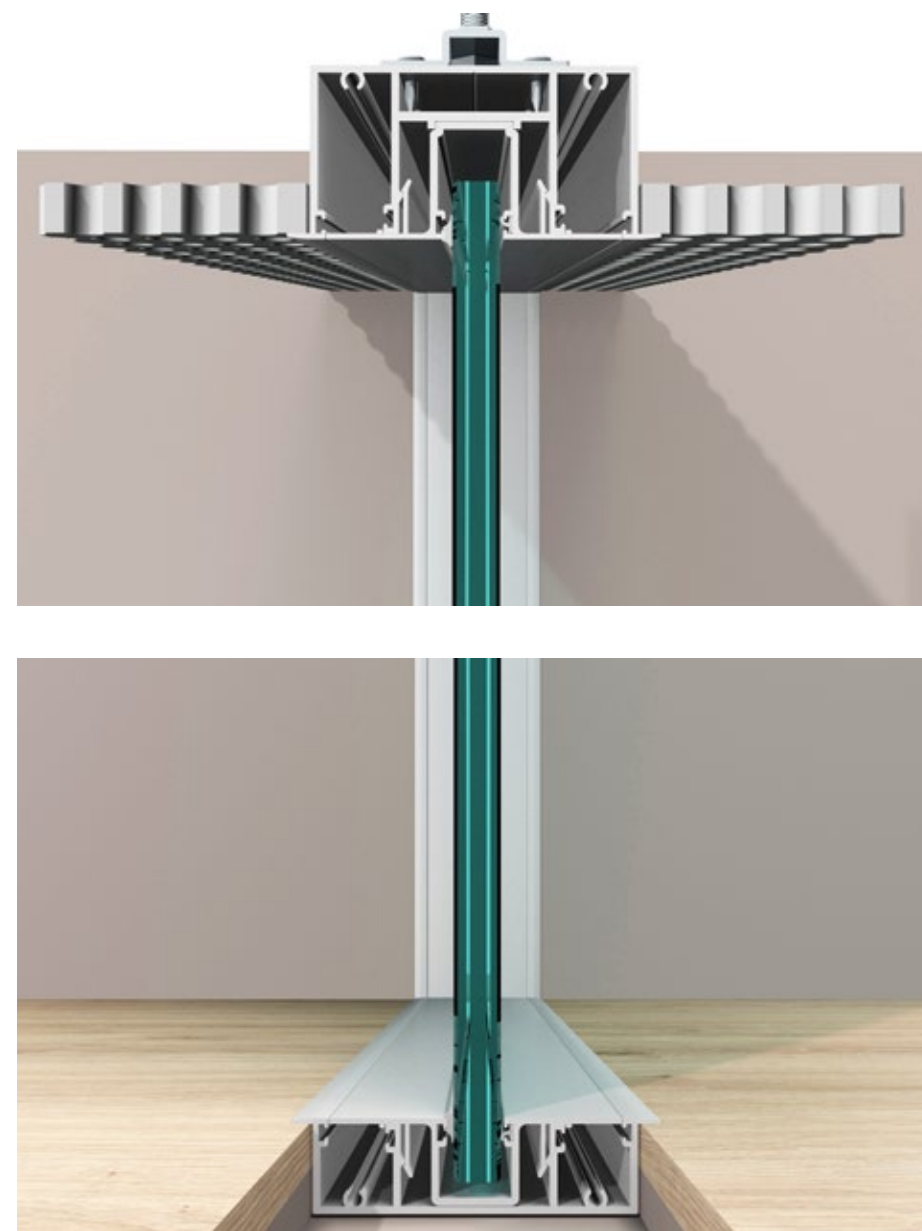

- metrica® d1
- metrica® d2
- metrica® solid
- metrica® f1**
- metrica® fA
- metrica® f2

metrica® f1

concealed profile - central glass

Asymmetrical single glazed partition.
 Concealed profile.
 5+5-mm or 6+6-mm thick laminated single glass.

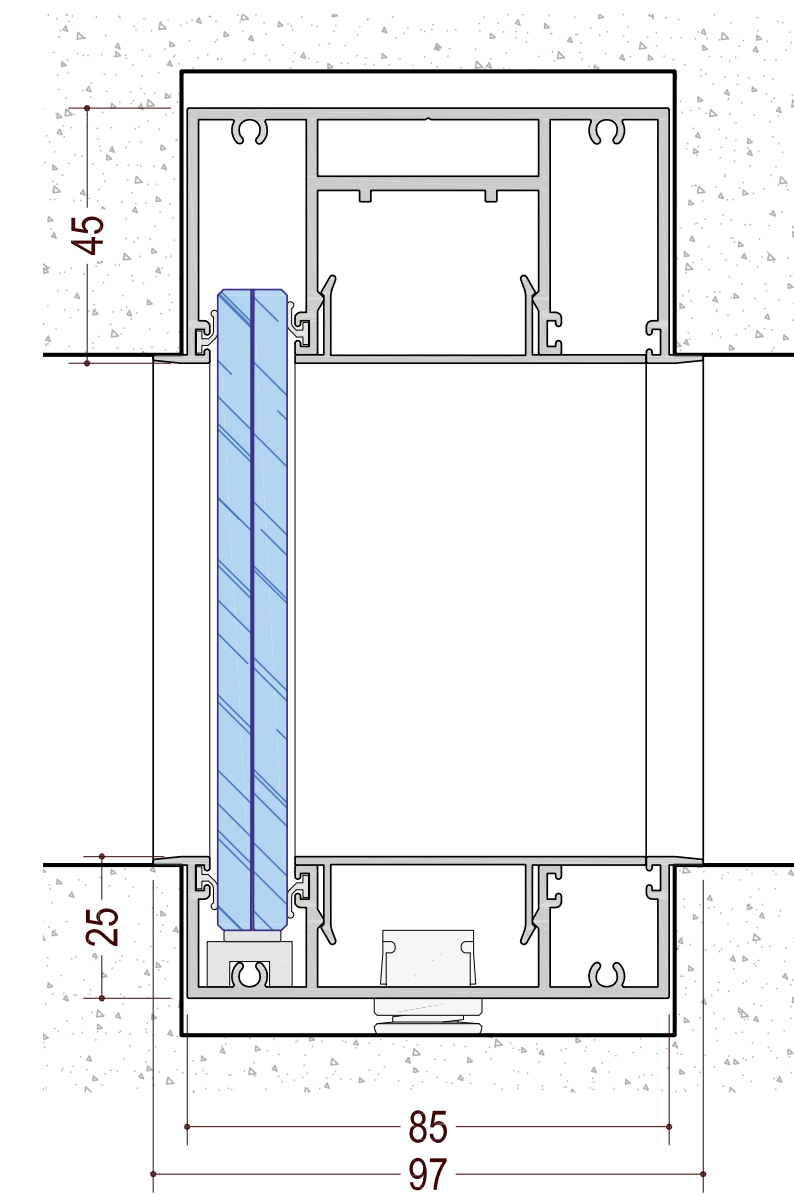
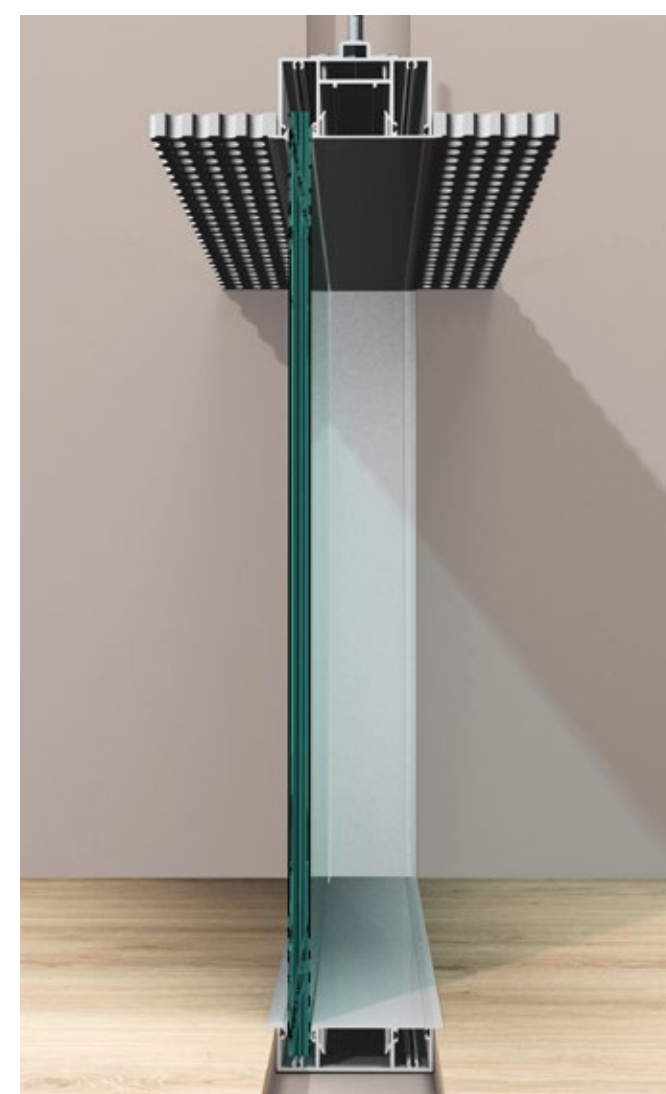
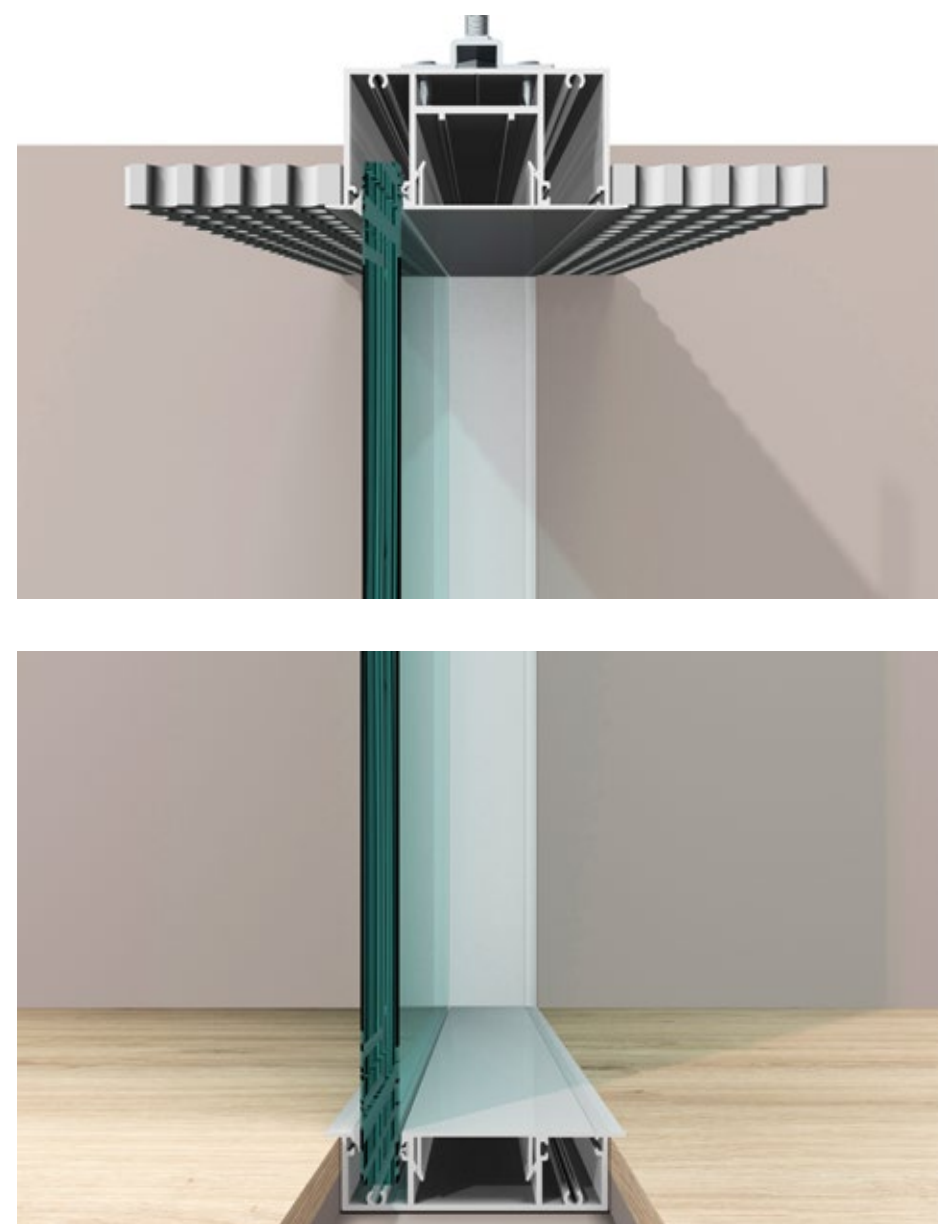

- metrica® d1
- metrica® d2
- metrica® solid
- metrica® f1
- metrica® fA**
- metrica® f2

metrica® fA

concealed profile - asymmetrical glass

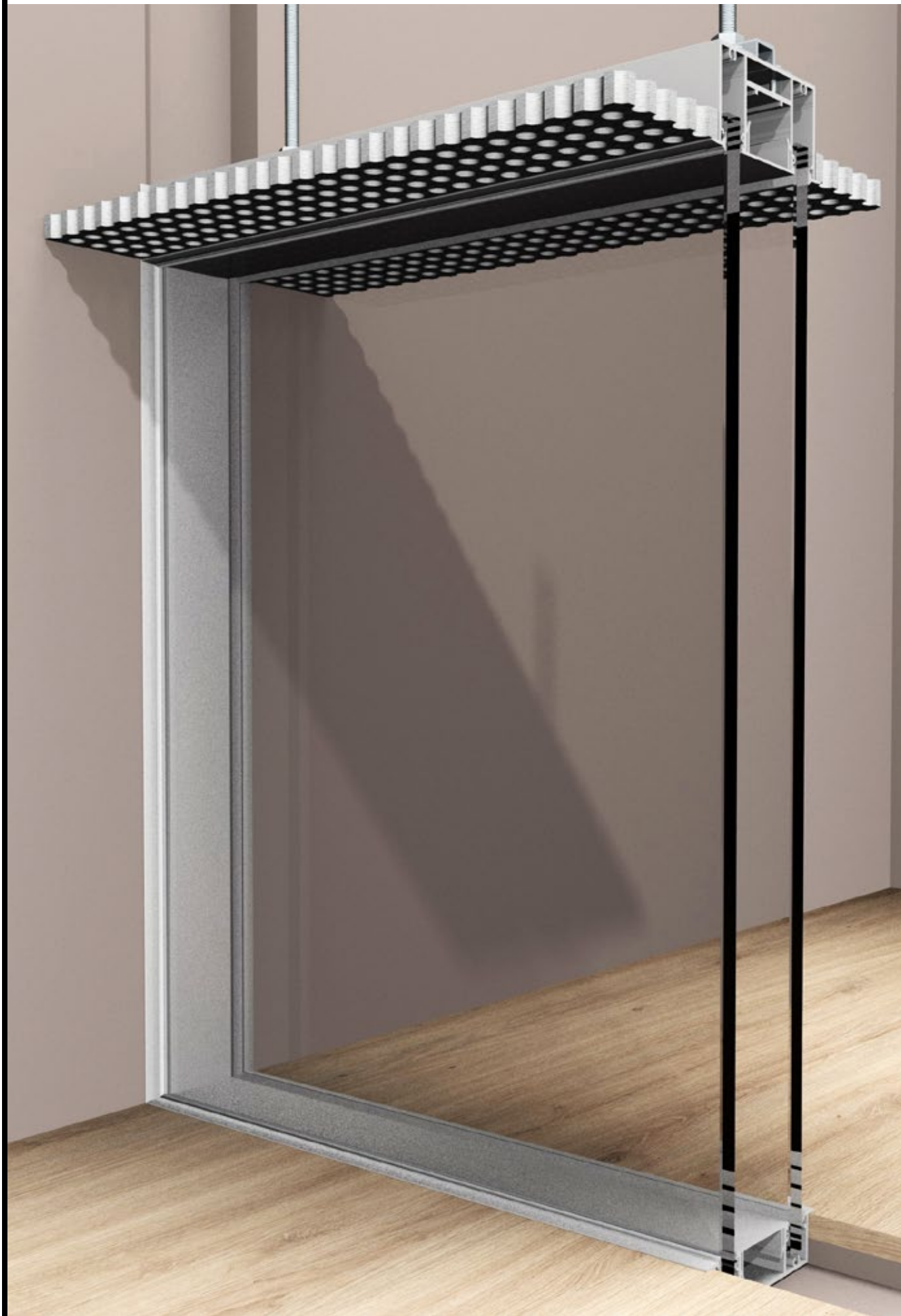

Double glazed partition.
 Concealed profile.
 5+5-mm or 6+6-mm thick laminated single glass.

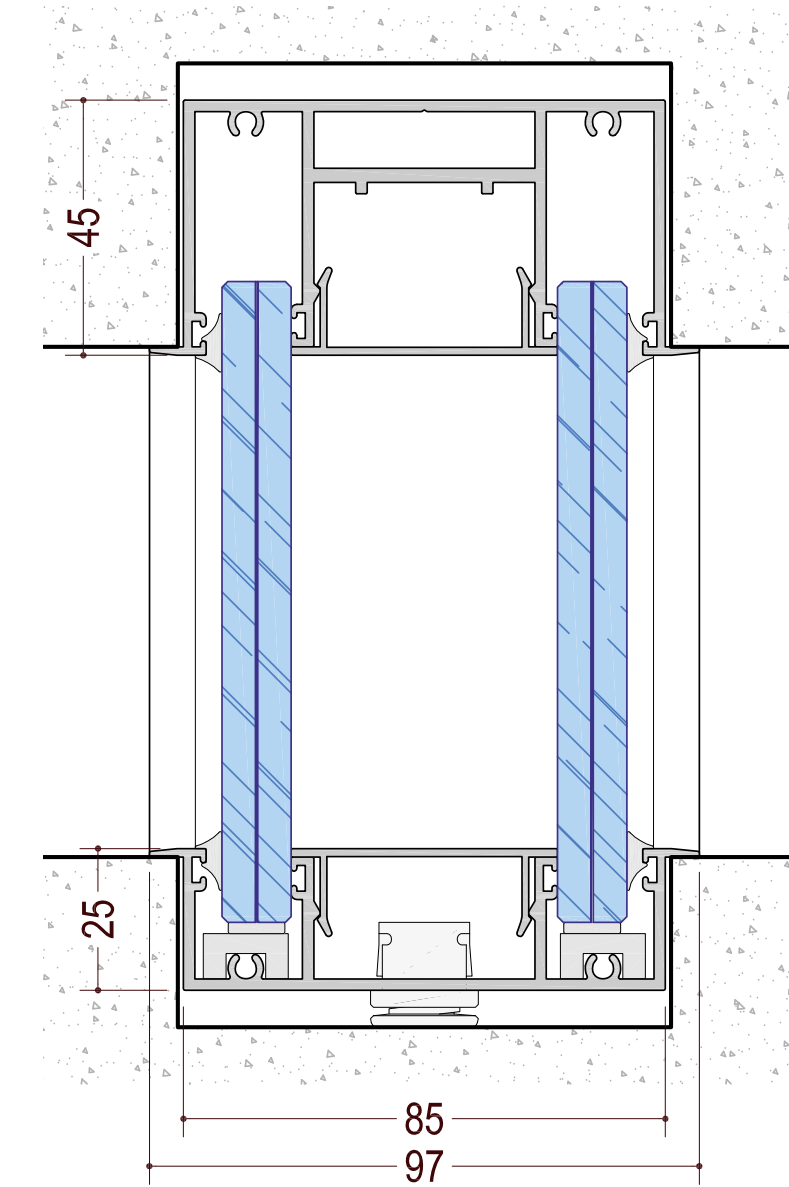
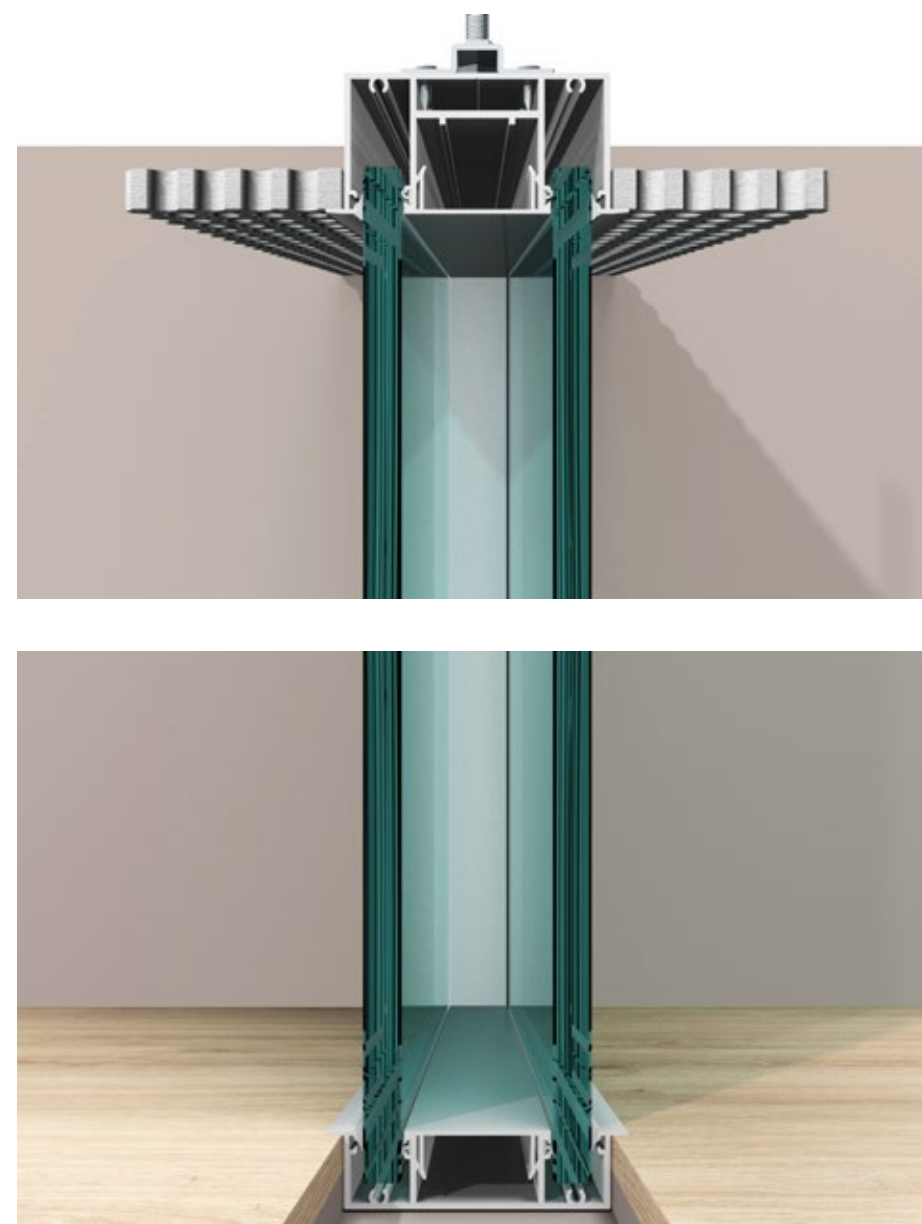

- metrica® d1
- metrica® d2
- metrica® solid
- metrica® f1
- metrica® fA
- metrica® f2**

metrica® f2

concealed profile - double glass



quadra®

Storage units

Depth, 362-462-600 mm

Quadra is a wide and flexible storage partition system. Its characteristics make it possible to fulfill any request for dividing spaces.

Corridors, pillars and work space coverings, customization of materials and finishes make it a highly versatile and modern product.

Quadra's assembly and disassembly ease allows rapid changes without hindering the normal course of business.

ETOILE

lafano
oltre l'ufficio



ETOILE

lafano
oltre l'ufficio

quadra®
Storage units
Depth, 362-462-600 mm

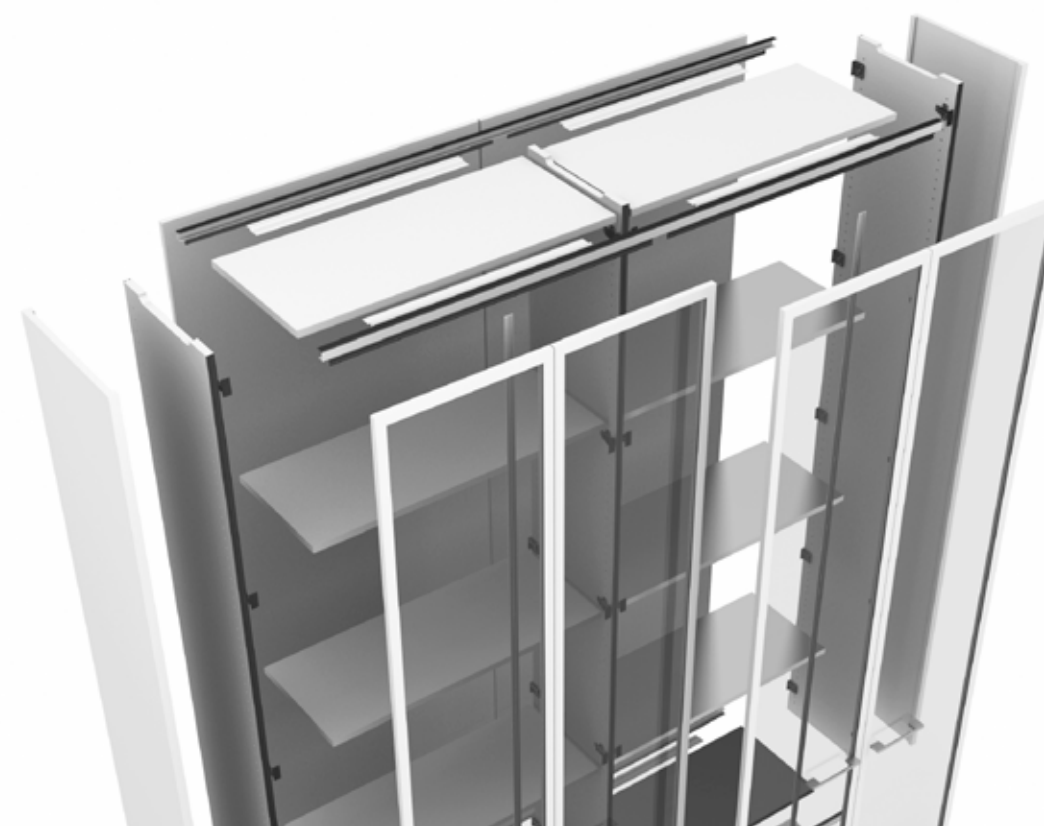

quadra® v
Framed glass doors.
Acoustic performance: from 39 to 44 dB.

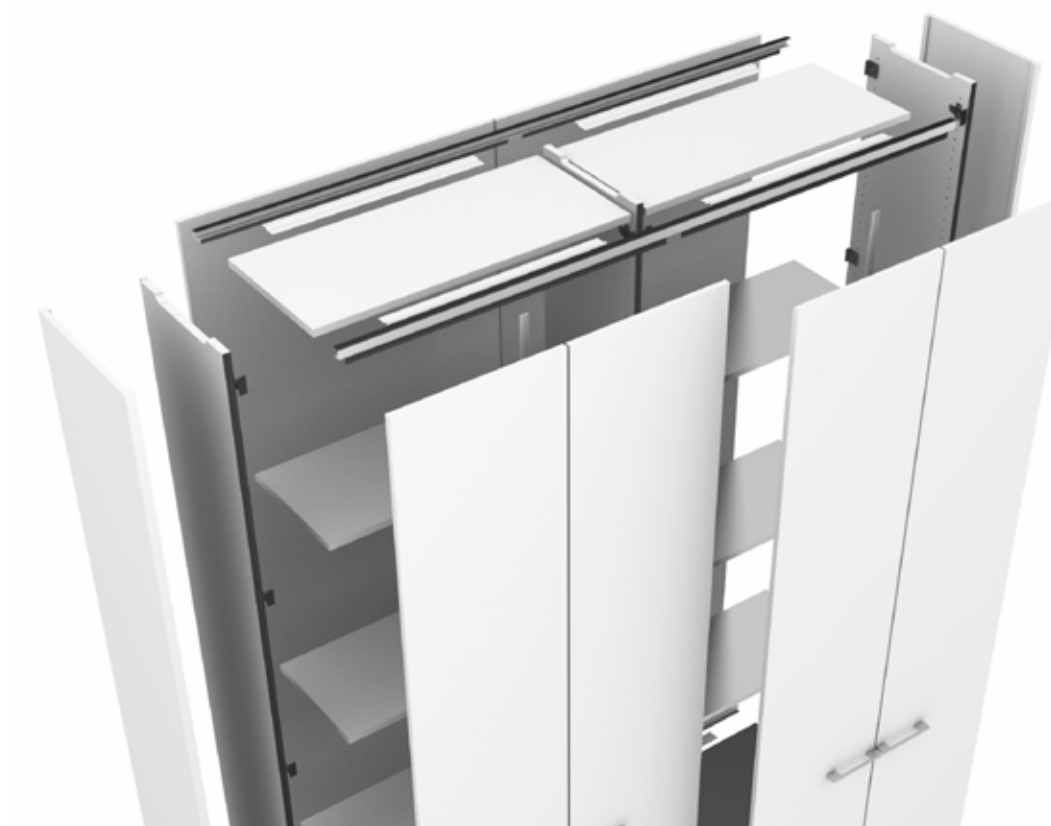

quadra® solid
Solid doors.
Acoustic performance: from 39 to 44 dB.

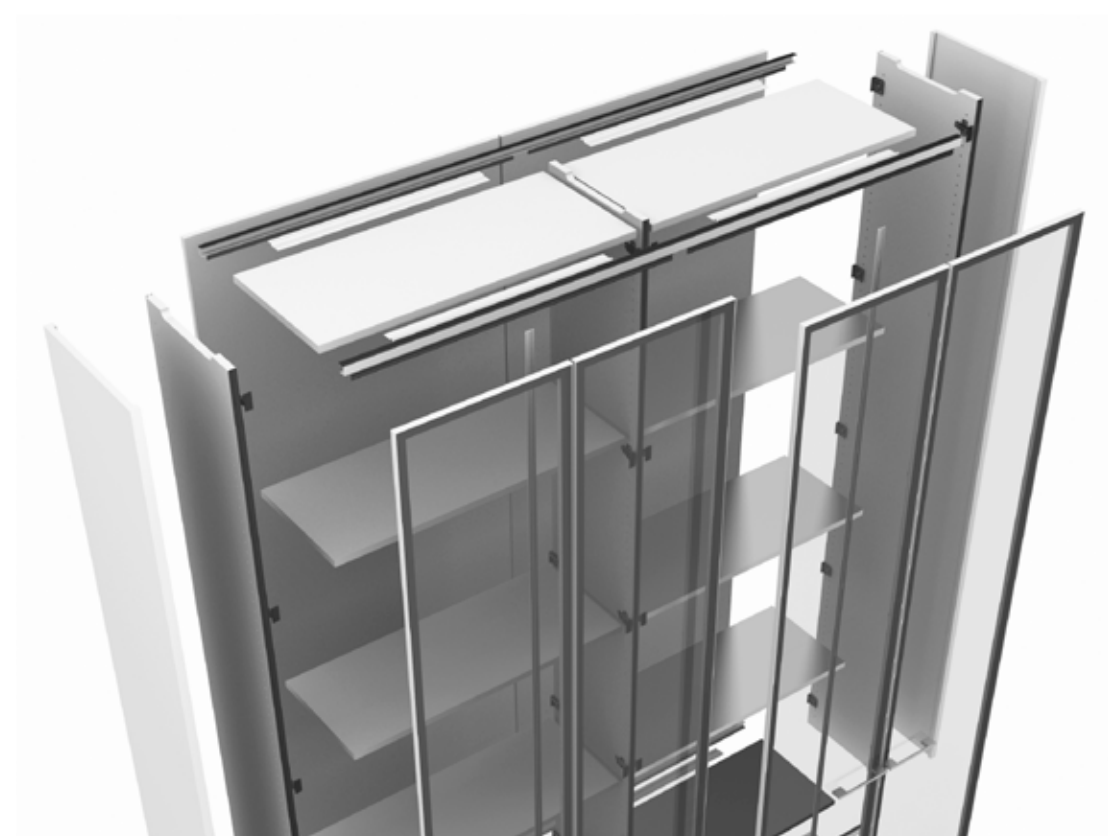

quadra® s
External-flush glass doors.
Acoustic performance: from 39 to 44 dB.



dodici[®] furniture collection

A range of executive and operative office desks, as well as meeting tables, composed of an aluminum structure + unicolor HPL worktop, wooden worktop or glass worktop, all 12-mm thick.

The collection is completed with drawers, service tables and wooden and metal storages.

ETOILE

lafano
oltre l'ufficio



dodici® workstations



dodici® meeting tables



ETOILE

lafano
oltre l'ufficio



dodici® executive desks

dodici®
furniture collection



ETOILE

 **lafano**
oltre l'ufficio

F I N I S H E S

ETOILE

lafano
oltre l'ufficio

FINISHES

FRAME

SOLID PANELS

- *unicolor*
- *wood finishes*
- *materic*

GLASS





FRAME

ANODISED

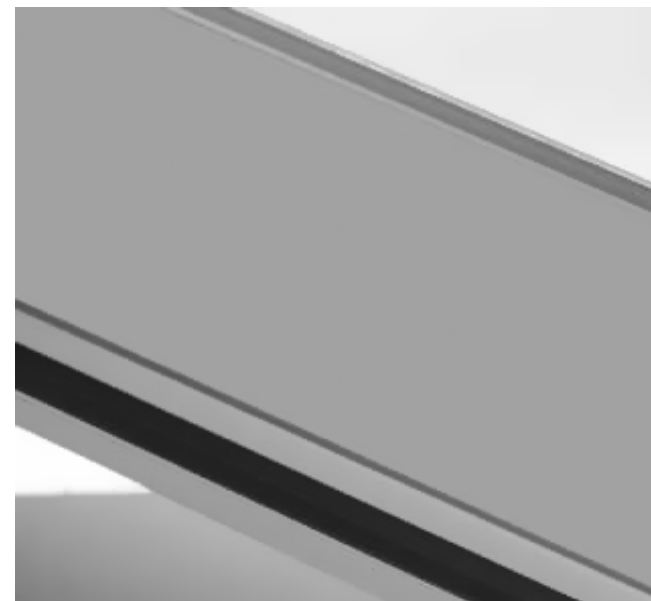

01 Natural aluminium

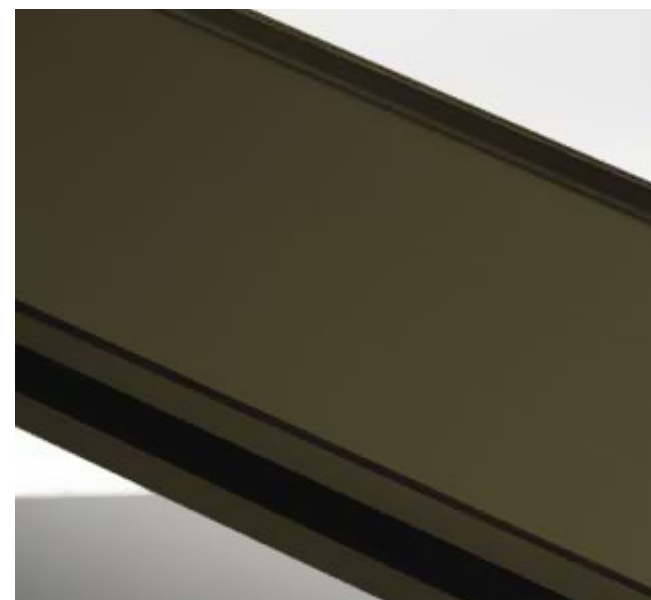

02 Bronze

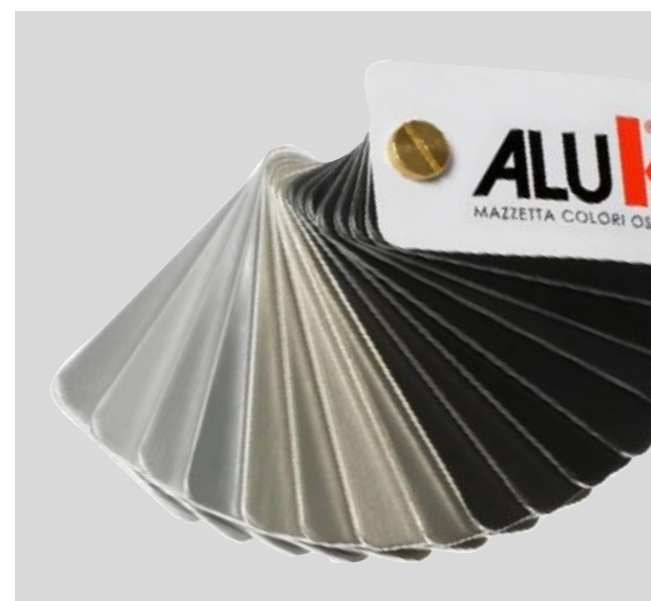

03 Other finishes

RAL FINISHES



01 White



02 Black



03 Other finishes

POLISH

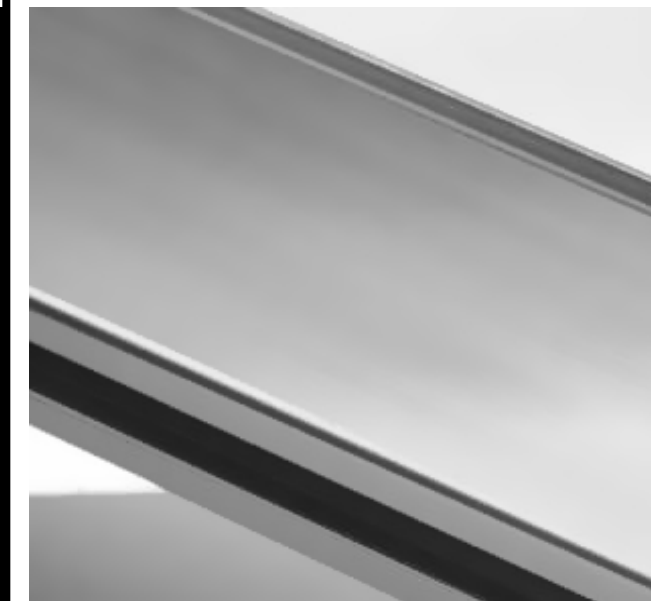

01 Shine

RITMICA WOOD



Light oak



Dark oak



SOLID
PANELS

UNICOLOR

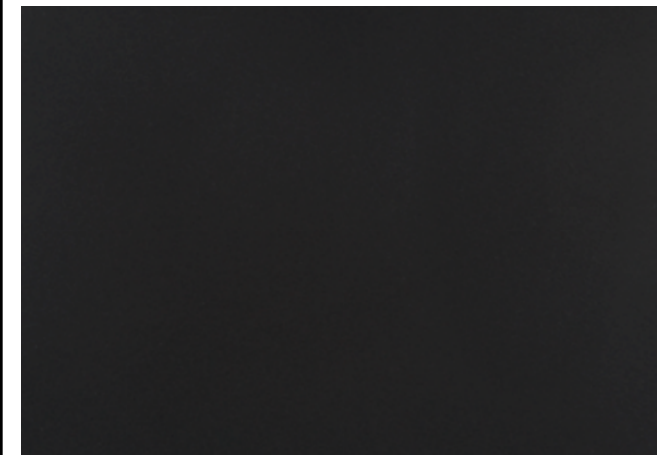

055 Graphite black



419 Light grey

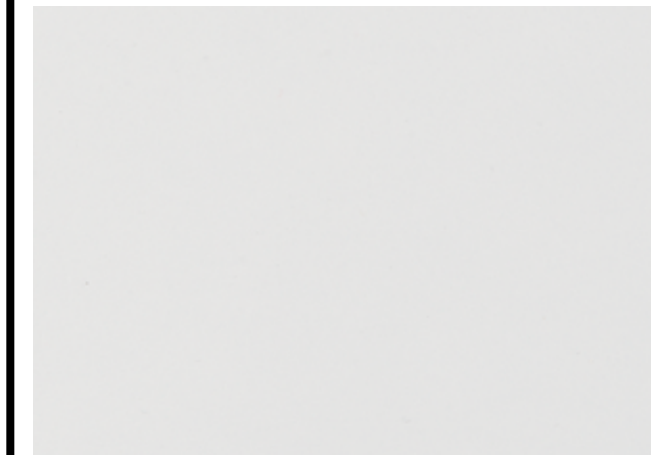

428 Cold white

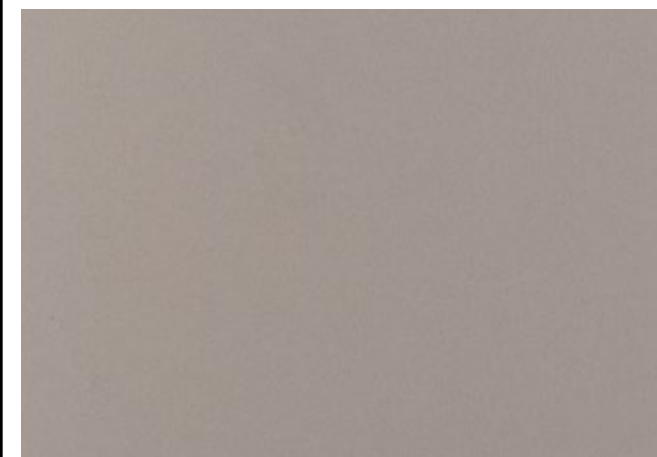

393 Dove grey

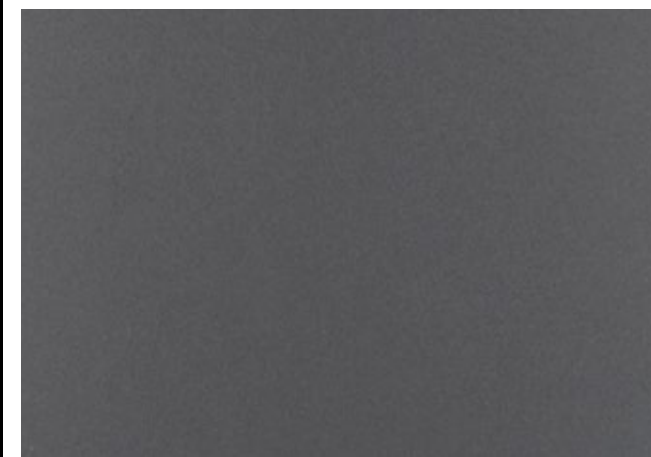

420 Gunmetal



429 Warm white



417 Vanilla

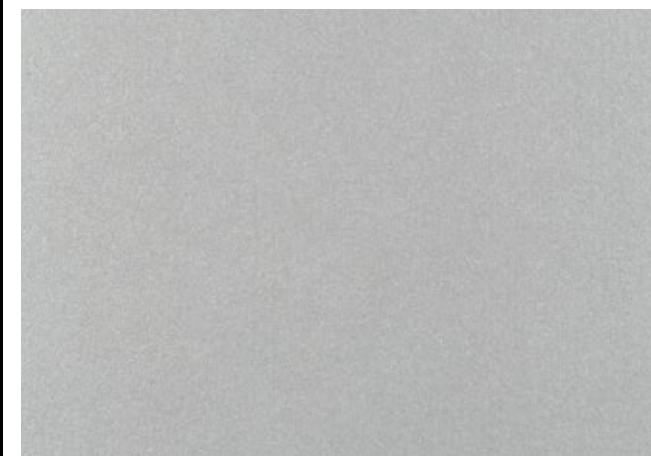

422 Silver



418 Ash grey

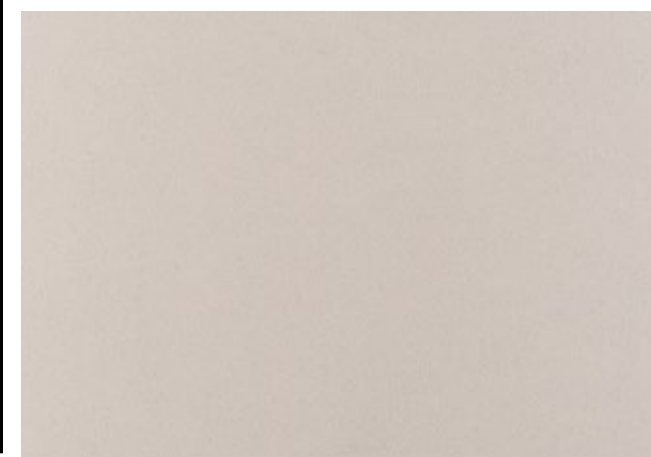

423 Champagne



SOLID
PANELS

WOOD
FINISHES



138 Aged saw-cut oak

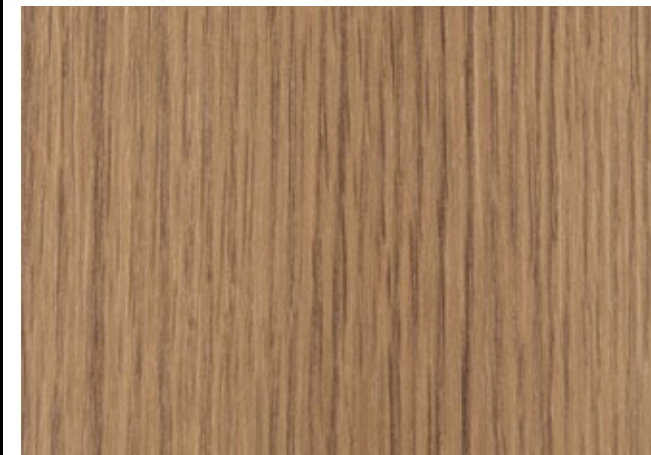

382 Natural oak



412 Vintage oak

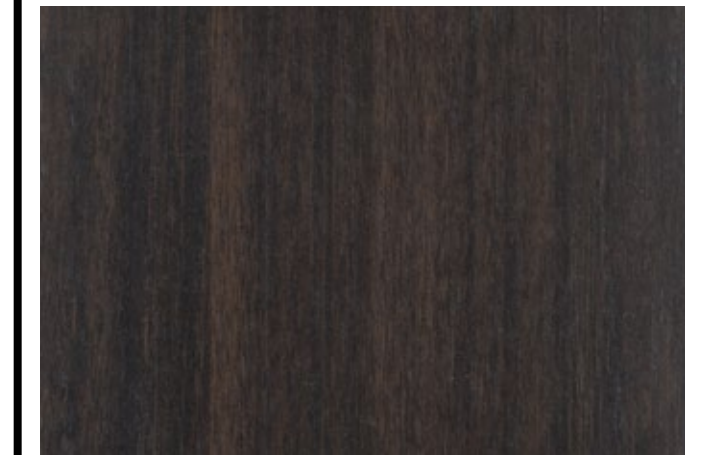

421 Eucaliptus

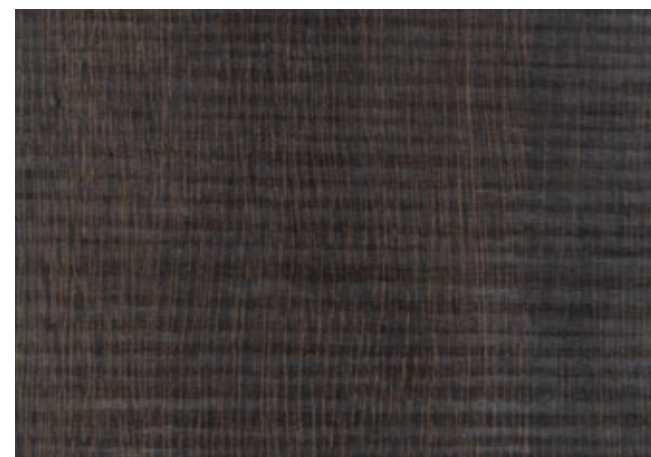

197 Saw-cut eucaliptus

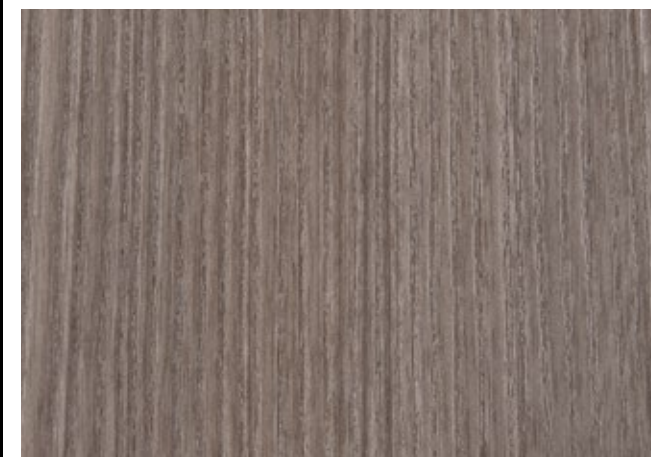

400 Danube oak

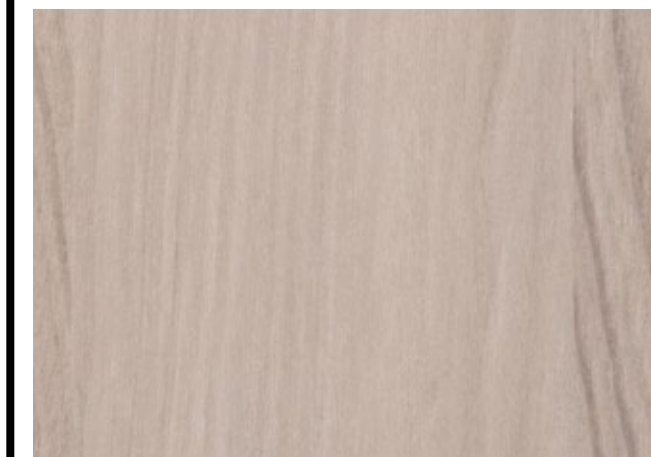

413 Champagne oak

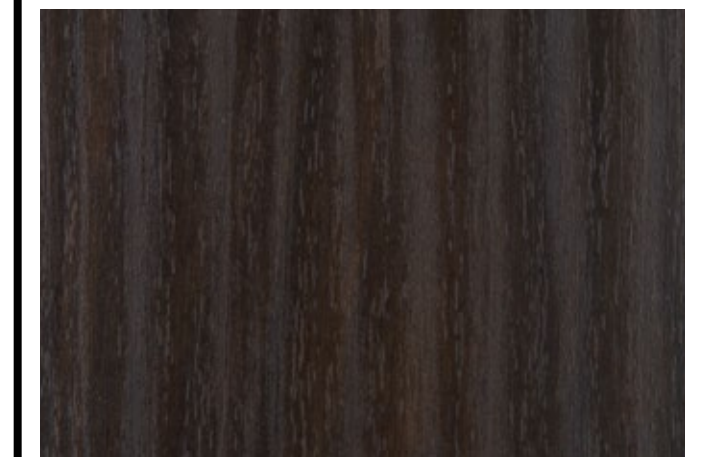

425 Dark walnut



274 Acacia

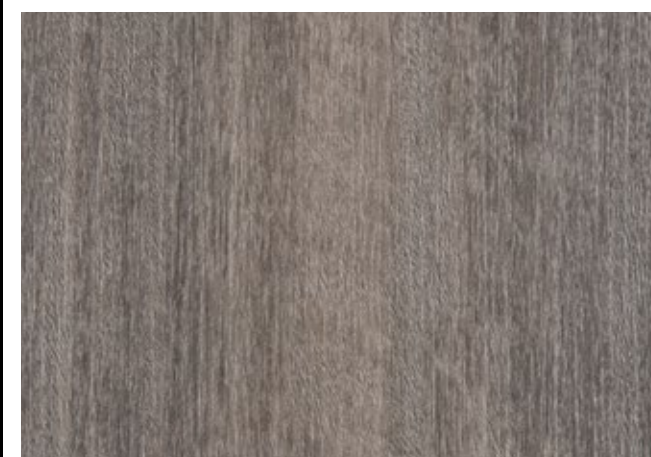

408 Grey oak

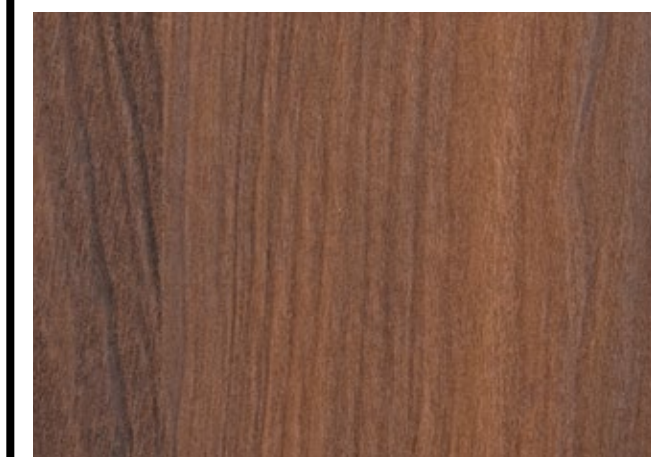

414 Red walnut

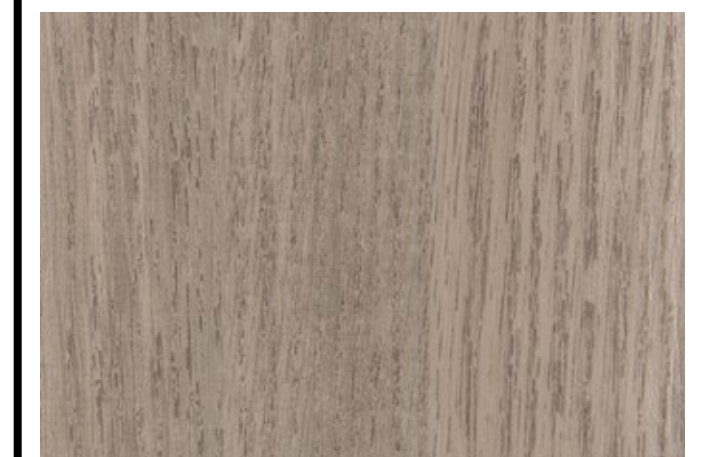

426 Mid-tone oak

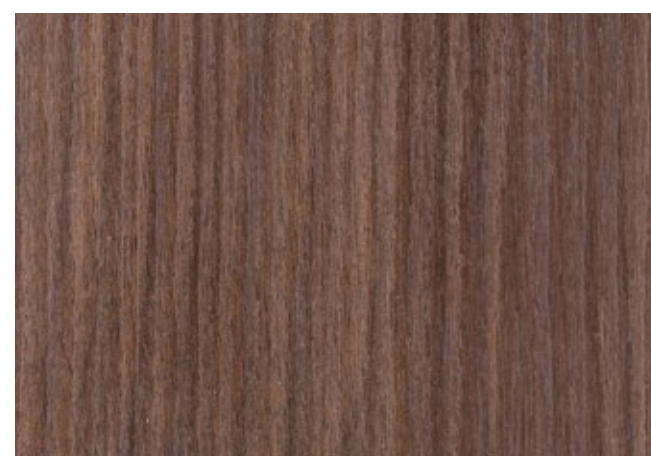

318 Mid-tone walnut

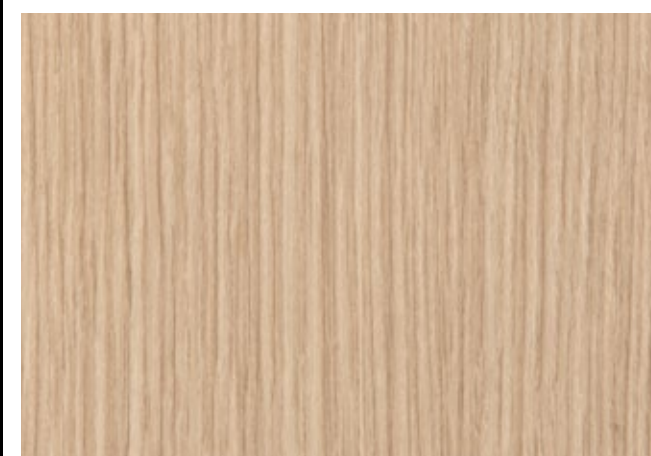

410 Light oak



416 Streaked white

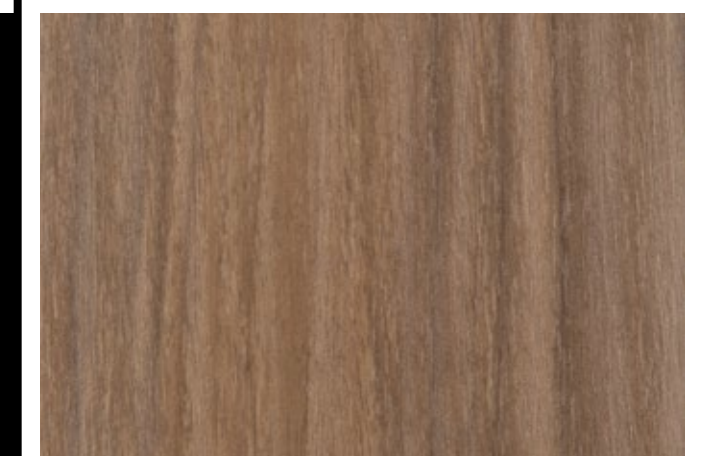

427 Light walnut



SOLID
PANELS
MATERIC



123 Mid-tone fabric

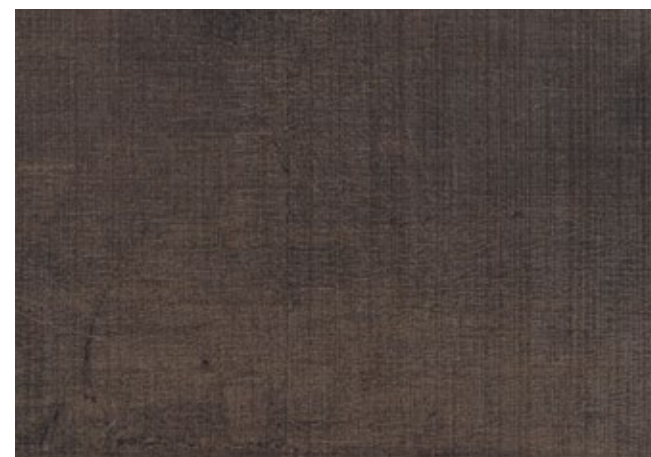

304 Dark-tone fabric

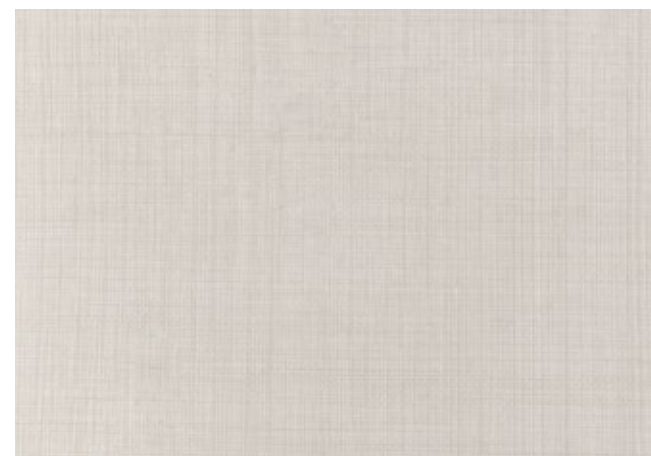

305 Light-tone fabric

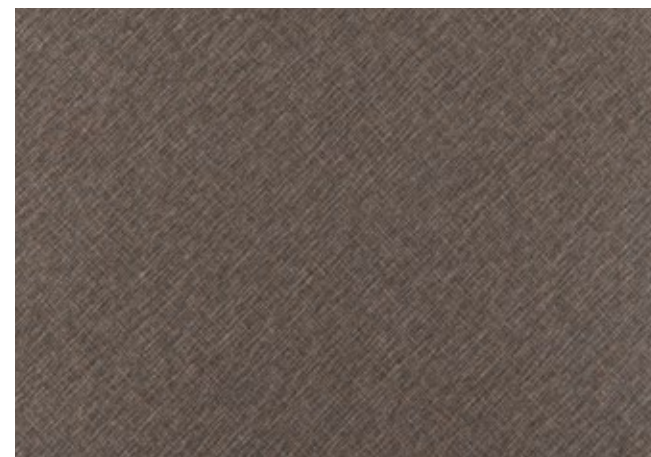

385 Bronze linen

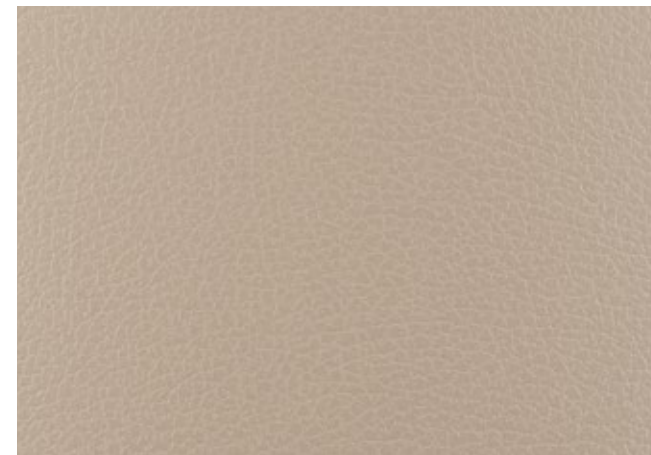

404 Primo fiore beige

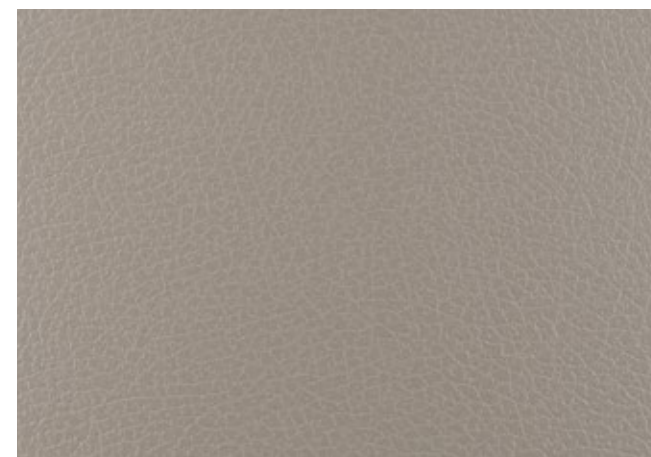

405 Primo fiore
dove grey

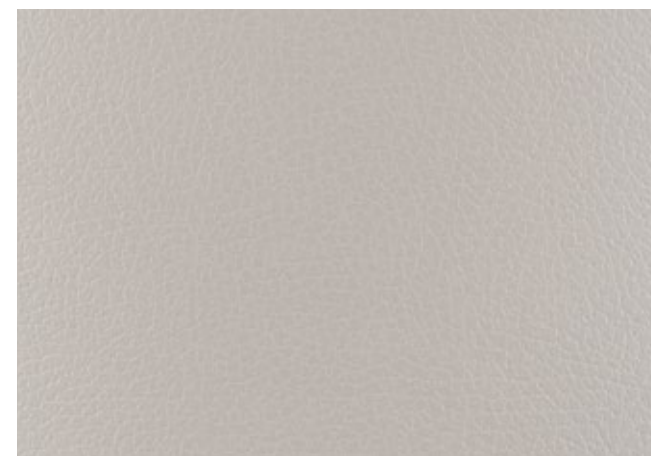

406 Primo fiore grey

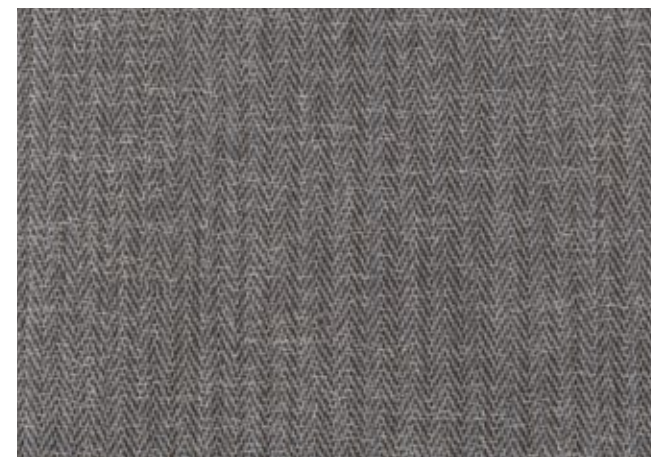

409 Bark



415 Desert

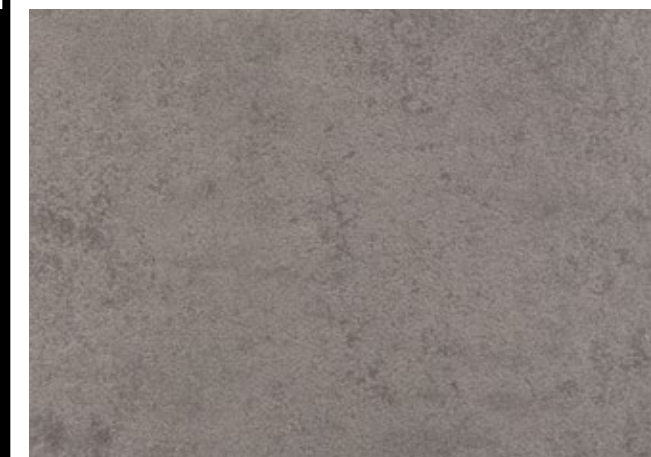

424 Oxide



GLASS



01 Clear



03 Satin



05 Smoked



02 Extra light

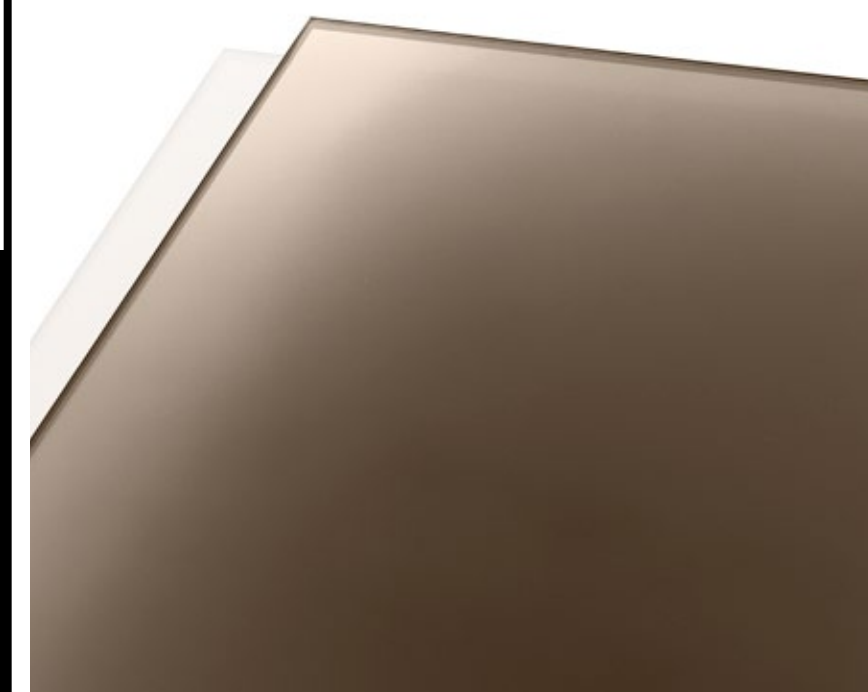

04 Bronze



05 Painted in all RAL colours